

## Heat Merchants Group Solar PV Systems

**NSAI Agrément (Irish Agrément Board)** is designated by Government to carry out European Technical Assessments. NSAI Agrément Certificates establish proof that the certified products are '**proper materials**' suitable for their intended use under Irish site conditions, and in accordance with the **Building Regulations 1997 to 2019**.



### PRODUCT DESCRIPTION:

This certificate relates to the Heat Merchants Group Solar PV systems utilising the Q-Cells Monocrystalline Solar PV modules.

The system is comprised of an array of photovoltaic solar modules, DC to AC inverter equipment and cables, on-roof fixing kit, user & installation manual and labelling packs.

In the opinion of NSAI, the Heat Merchants Group Solar PV Systems, as described in this Certificate, comply with the requirements of the Building Regulations 1997 to 2019.

### USE:

The Heat Merchants Group solar PV modules are suitable for application on new and existing buildings with a roof pitch range of between 5° - 70°. The modules must be fixed to a roof that meets the requirements of SR 82<sup>[1]</sup>. In addition, all relevant aspects related to the fixing of the PV panel to the roof structure shall be designed and installed to comply with SR 50-2<sup>[7]</sup>.

The solar PV systems should be installed by a competent person with suitable training and practical experience of the systems and have been approved by Heat Merchants Group to install the system.

### MARKETING, DESIGN AND MANUFACTURE:

Heat Merchants Group solar PV modules are manufactured on behalf of:

Heat Merchant Group  
Moydrum Road  
Athlone  
Co. Westmeath  
Tel: 090 6424000  
E-mail: [info@heatmerchants.ie](mailto:info@heatmerchants.ie)  
Web: [www.heatmerchants.ie](http://www.heatmerchants.ie)

Heat Merchants Group also design, market and distribute the Heat Merchants Group Solar PV Systems.

### 1.1 ASSESSMENT

In the opinion of NSAI Agrément, the Heat Merchants Group solar PV systems, if used in accordance with this certificate can meet the requirements of the Building Regulations 1997 to 2019, as indicated in Section 1.2 of this Agrément certificate.

### 1.2 BUILDING REGULATIONS 1997 to 2019

#### REQUIREMENTS:

#### **Part D – Materials and Workmanship** **D3 – Proper Materials**

The Heat Merchants Group solar PV systems, as certified in this certificate, are comprised of 'proper materials' fit for their intended use (see Part 4 of this Certificate).

#### **D1 – Materials & Workmanship**

The Heat Merchants Group solar PV systems, as certified in this certificate, meet the requirements for workmanship.

#### **Part A – Structure**

##### **A1 – Loading**

The Heat Merchants Group solar PV systems, once appropriately designed and installed in accordance with this certificate, have adequate strength and stability to meet the requirements of this Regulation (see Part 3 of this certificate).

#### **Part B – Fire Safety/Vol 2 (Dwelling Houses)** **B4/B9 – External Fire Spread**

The Heat Merchants Group solar PV systems will not affect the external fire rating of the roof structure on which they are installed (see Part 4 of this certificate).

#### **Part C – Site Preparation and Resistance to Moisture**

##### **C4 – Resistance to Weather and Ground Moisture**

The Heat Merchants Group solar PV systems once appropriately designed and installed in accordance with this certificate, will not affect a roof's resistance to the ingress of moisture (see Part 4 of this certificate).

#### **Part L – Conservation of Fuel and Energy**

##### **L1 – Conservation of Fuel and Energy**

The Heat Merchants Group solar PV systems can be designed to meet the minimum level of energy provision from renewable technologies stated in this Regulation contributing to electrical energy use for domestic buildings.

The Heat Merchants Group Solar PV technology referenced on this certificate can contribute to the Renewable Energy Ratio (RER) requirements of TGD Part L Non-Domestic Energy Assessment Procedure (NEAP). The RER is the ratio of primary energy from renewable energy sources to total primary energy.

## 2.1 PRODUCT DESCRIPTION

This certificate relates to the Heat Merchants Group solar PV systems utilising a Monocrystalline range of photovoltaic (PV) modules and ancillary items.

Figure 1 shows the main elements of the Heat Merchants Group solar PV system. Tables 1 and 2 highlight the Solar PV systems range and technical specifications.

The Heat Merchants Group Electrical PV modules have been tested to the requirements of I.S. EN 61215<sup>[2]</sup>.

### 2.1.1 Heat Merchants Group Solar Photovoltaic Modules

NSAI ensures that the manufacturing process of the PV modules is audited annually to ensure on-going quality of the products. The solar PV module manufacturer has also been assessed and approved to MCS 010<sup>[3]</sup>.

Heat Merchants Group offer two cell-sized PV modules: 120 half cells and 144 half cells. These PV modules consist of six strings of PV cells in monocrystalline. The front cover consists of 3.2mm thick tempered glass and the rear coating consists of layers of specialist polymers. The frame of the PV modules consists of a 3.2mm anodized aluminium alloy. The junction box on the PV module has a minimum protection class of IP67.

The modules operate by daylight, entering the solar cells causing movement of electrons which generates an electrical DC current.

The PV modules can be arranged into an array of variable size, depending on the requirements of the design and the available mounting space.

### 2.1.2 Inverters

A DC/AC inverter is required to convert the direct current (DC), generated by the PV modules into a usable alternating current (AC) so the power produced by the PV modules can be used by the electrical appliances in the building. The certificate holder offers the Solis String Inverter for this purpose.

The inverter specified by Heat Merchants Group sized according to the number of PV modules required in the design.

#### 2.1.2.1 String Inverters

With residential string inverters, all solar PV modules are connected in a DC circuit, which is then connected to a single inverter.

The string inverter should be mounted at a suitable location in an accessible loft space or beside the property's main AC consumer unit. String inverters produce power at a slightly higher voltage than the grid. The inverter is wired back to the consumer unit where it delivers power to the electric loads within the building or exported.

The maximum number of panels that can be installed using a string inverter is limited by the kW capacity of the inverter. All DC and AC cabling must be sized correctly to carry the electrical load from the panels, back to the inverter which is then wired to the consumer board.

#### 2.1.2.2 Ancillary Products

- Solarflash by Genius Roof Solutions.
- Dektite solar flashing.

The Ancillary products listed have not been assessed by NSAI Agrément and remain under the manufacturer's responsibility.

## 2.2 MANUFACTURE AND OPERATION

The Heat Merchants Group solar PV modules consist of monocrystalline designs, available in three different cell configurations (See Tables 1 and 2):

- 6 x 20 split cells.
- 6 x 22 split cells.
- 6 x 24 split cells.

The cells used in the Monocrystalline PV module are manufactured from a large single silicon crystal. The monocrystalline PV module contain cells measuring 156mm x 156mm squares, which are housed in an anodized aluminium alloy frame complete with 3.2mm toughened glass.

## 2.3 DELIVERY, STORAGE AND HANDLING

Heat Merchants Group supply a complete package for each PV system, which includes the PV modules, inverters, electrical isolators, roof mounting kit, user & installation manual and safety labelling packs.

PV Modules should always be stored indoors, preferably in a vertical position, otherwise on the flat (frame on frame) ensuring no weight is applied to the wafer area, with the glass facing upwards. Heavy goods should not be loaded on top of the kit boxes. Care should be taken when opening boxes to prevent scratches or sudden shocks to the flat panels. Associated components also supplied should be stored in a clean, dry and frost-free environment until ready for installation. Parts should be inspected for damage on arrival to site. Current health and safety legislation apply to these products with regard to safe lifting and manual handling.

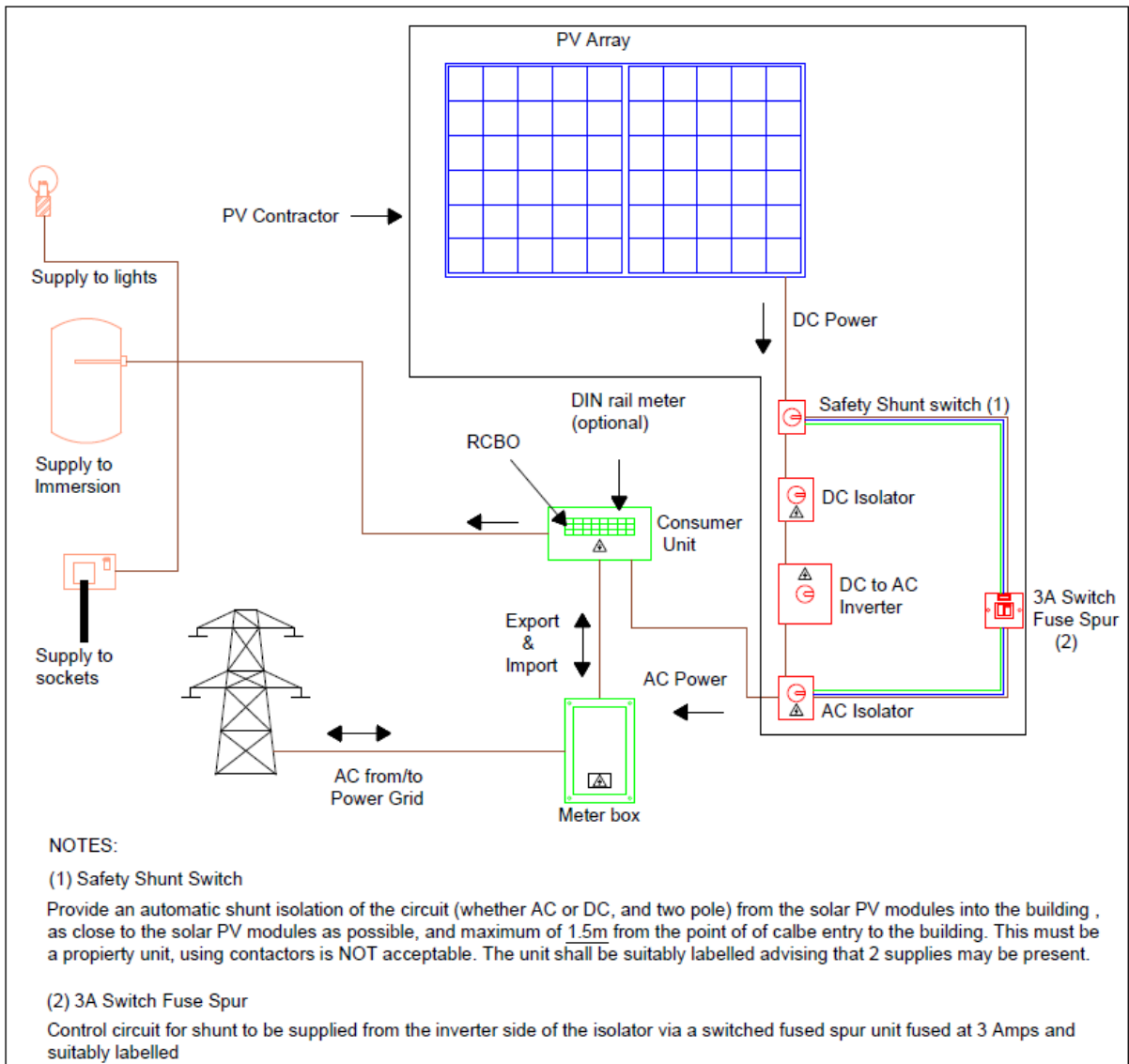

**Figure 1: System Components**

Photovoltaic panel type	Monocrystalline	Monocrystalline	Monocrystalline	Monocrystalline
	6 x 20 Mono Q.ANTUM Half Cells	6 x 20 Mono Q.ANTUM Half Cells	6 x 24 Mono Q.ANTUM Half Cells	6 x 22 Mono Q.ANTUM Half Cells
Panel length (up roof) (m)	1.685	1.74	2.08	1.84
Panel width (across roof) (m)	1	1.03	1.03	1.03
Panel Thickness (mm)	32	32	35	32
Aperture area (m <sup>2</sup> )	1.685	1.7922	2.14	1.895
Panel weight (kg)	19.9kg	19.9kg	24.5kg	19.5kg

**Table 1: PV Module Specification**

Table 2: Electrical Characteristic /Performance <sup>(1)</sup> – PS range of Monocrystalline Panels

Photovoltaic panel type	Q.PEAKDUO-G5-325W	Q.PEAKDUO-G6-355W	Q.PEAKDUO-G7-330W	Q.PEAKDUO-G8-345W	Q.PEAKDUO-G8-350W	Q.PEAKDUO-G8+-350W	Q.PEAKDUO-G8+-360W	Q.PEAKDUO-BLK-G6-335	Q.PEAKDUO-BLK-G8-340	Q.PEAKDUO-BLK-G8-345	Q.PEAKDUO-BLK-G8+-335	Q.PEAKDUO-BLK-G8+-340	Q.PEAKDUO-BLK-G8+-345	Q.PEAKDUO-G8L-420W	Q.PEAKDUO-G8L-425W	Q.PEAKDUO-MLG9-370W	Q.PEAKDUO-MLG9-375W	Q.PEAKDUO-MLG9-380W	Q.PEAKDUO-MLG9+-370W	Q.PEAKDUO-MLG9+-375W	Q.PEAKDUO-MLG9+-380W
Frame	Black	Black	Black	Black	Black	Black	Black	Black	Black	Black	Black	Black	Black	Black	Black	Black	Black	Black	Black	Black	Black
Backsheet	White	White	White	White	White	White	White	Black	Black	Black	Black	Black	Black	White	White	White	White	White	White	White	White
Number of Cells	120	120	120	120	120	120	120	120	120	120	120	120	120	144	144	132	132	132	132	132	132
Nominal peak power rating	325	355	330	345	350	350	360	335	340	345	335	340	345	420	425	370	375	380	370	375	380
Tolerance (%)	0 to +5	0 to +5	0 to +5	0 to +5	0 to +5	0 to +5	0 to +5	0 to +5	0 to +5	0 to +5	0 to +5	0 to +5	0 to +5	0 to +5	0 to +5	0 to +5	0 to +5	0 to +5	0 to +5	1 to +5	2 to +5
Open circuit voltage (V)	40.40	40.98	40.62	40.45	40.70	40.70	41.19	40.41	40.70	40.95	40.44	40.70	40.95	48.84	49.09	44.92	44.96	44.99	44.92	44.96	44.99
Maximum power voltage	33.65	34.39	34.14	33.92	34.24	34.24	34.85	33.62	34.34	34.65	34.01	34.34	34.65	41.08	41.39	36.90	37.18	37.46	36.90	37.18	37.46
Short circuit current (A)	10.14	10.84	10.15	10.68	10.74	10.74	10.84	10.47	10.40	10.45	10.34	10.40	10.45	10.74	10.78	10.58	10.62	10.65	10.58	10.62	10.65
Maximum power current	9.66	10.33	9.67	10.17	10.22	10.22	10.33	9.97	9.90	9.96	9.85	9.90	9.96	10.22	10.27	10.03	10.09	10.14	10.03	10.09	10.14
Module efficiency (%) <sup>(2)</sup>	≥19.3	≥19.8	≥19.6	≥19.3	≥19.5	≥19.5	≥20.1	≥18.7	≥19.0	≥19.3	≥18.7	≥19.0	≥19.3	≥19.6	≥19.8	≥19.5	≥19.8	≥20.1	≥19.5	≥19.8	≥20.1
Maximum System voltage	1000	1000	1000	1000	1000	1000	1000	1000	1000	1000	1000	1000	1000	1000	1000	1000	1000	1000	1000	1000	1000
Series fuse rating (A)	20	20	20	20	20	20	20	20	20	20	20	20	20	20	20	20	20	20	20	20	20

(1) Performance of standard test conditions: irradiance 1000W.m<sup>-2</sup>, cell temperature 25°C, AM 1.5 spectrum.

(2) Based on aperture area.

Note: the watt rating of the PV modules are increasing annually due to improvements in technology, manufacturing processes and efficiencies. The watt rating of the PV modules is likely to increase after the date this document has been published.

**Table 2: Electrical Characteristic / Performance  
PS Range of Monocrystalline Panels**

	Orientation of module				
Tilt of Module	South	SE/SW	E/W	NE/NW	North
Horizontal	963				
15°	1036	1005	929	848	813
30°	1074	1021	886	736	676
45°	1072	1005	837	644	556
60°	1027	956	778	574	463
75°	942	879	708	515	416
Vertical	822	773	628	461	380

Taken from Table H2 , DEAP Manual<sup>[23]</sup>

**Table 3: Annual Solar Radiation, kWh/m<sup>2</sup>**

Over Shading	% sky blocked by obstacles	Overshading Factor
Heavy	>80%	0.50
Significant	60% - 80%	0.65
Modest	20% - 60%	0.80
None or Very Little	< 20%	1.00

<sup>(1)</sup> Taken from Table H3, DEAP Manual<sup>[23]</sup>

**Worked DEAP<sup>[23]</sup> Example**

Output (kWh) = 0.8 x kWp x S x Z<sub>DV</sub>

**Where:**

KWp = installed peak power

S = annual solar radiation

Z<sub>DV</sub> = over shading factor (from DEAP<sup>[23]</sup> manual, Table H3, typically a value of 1 were placed on a roof with no shading)

**Example calculation**

For an array of 4 monocrystalline silicon panels each with a nominal peak power of 300 Wp (i.e. nominal peak power rating for the Q-PeakDuo-G5-325w panel per Table 2), mounted on a roof with a 30° pitch facing directly south with no overshadowing, the total installed capacity would be:

Installed peak power: 0.325 x 4 = 1.30 kWp (325Wp=0.325kWp, x No. of panels in array).

The annual approximated output would be: 0.8 x 1.30 x 1,074 x 1 = 1117 kWh.

\*This calculation method is as per the SEAI DEAP<sup>[23]</sup> method and tables

**Table 4: Overshading Factors from SEAI DEAP Manual**

## 2.4 INSTALLATION

### 2.4.1 General

The details in this certificate should not be considered a definitive set of installation instruction, but an overview of the procedures involved. Should a conflict arise between this certificate and the certificate holders manuals, this certificate takes precedence.

The Heat Merchants Group solar PV systems should be installed by a REC registered electrical contractor with suitable training and practical experience of the systems and who have been approved by Heat Merchants Group to install the system.

Solar PV panel installation must be performed in accordance with all Health & Safety legislation and building/planning regulations, and must comply with I.S. 10101<sup>[4]</sup> for the system components, including the cables, connectors, charging controllers, inverter, etc.

Under normal conditions, a module is not likely to produce more current and/or voltage than reported under standard test conditions (stc). Accordingly, the values of current short circuit (Isc) and voltage open circuit (Voc) marked on the module nameplate should be multiplied by the following safety factors:

- Voltage > Voc(stc) x M x 1.15;
- Current > Isc(stc) x N x 1.25.

Where M is the number of series connected modules, and N is the number of parallel connected strings'.

#### **Example calculation**

(for the Q.PEAKDUO-G5-325W panel per Table 2)

- 2 strings of 6 PV panels
- 33.65 Voc, 10.14 Isc, from PV Module datasheet

$$33.65 \times 6 \times 1.15 = 232 \text{ Vmin}$$

$$10.14 \times 1 \times 1.25 = 12.6 \text{ Imin}$$

All electrical components on the circuit must have a voltage and current rating greater than 273V D.C. and have a current carrying capacity of greater than 12.6 amps.

Heat Merchants Group can be contacted for guidance when determining the component voltage ratings, conductor current ratings, fuse sizes and the size of controllers connected to the photovoltaic system. Care is required when working with electric cables. Electrical connectors should never be opened or unplugged while the circuit is under load (when there is direct light on the panels). Extreme care should also be exercised not to touch the live cables during installations when the modules are exposed to daylight.

To protect the installer from current and voltage shock during installation, the DC cables should be first safely fitted into a junction box in the building before connecting the PV modules.

In addition, an opaque board can be used to cover the modules while making electrical connections. Only industry approved insulated tools shall be used during installation.

Earthing of the metallic parts of the solar PV modules and mounting system should be made in accordance with I.S. 10101<sup>[4]</sup>. In general, where there are no adjacent metallic elements of the building (e.g. structural steel or piping) that are connected to the building earth, no additional equipotential bonding or connections to building earth are required. - Installation of solar PV systems in domestic properties does not generally increase the level of risk from lightning, particularly as modules tend to be located below ridge level and are not higher than the chimney. The risk of lightning should be assessed for individual buildings in accordance with EN 62305-1<sup>[5]</sup>. Where a building has an existing lightning protection system, the solar PV modules and frame shall be bonded to the lightning protection system with an appropriately sized conductor.

The Heat Merchants Group inverters comply with the conditions specified in I.S. EN 50438<sup>[6]</sup>. The inverters are either pre-set or have the Ireland country code option in their setup menu. Installers must check the correct option is selected.

For safety, the inverters require a small mains current to operate, and in the event of loss of mains supplied electricity, they will not generate electricity.

Fixings used with the PV solar panels must comply with Clause 4.11 (fittings) and 5.9 (battens and counter-battens) of SR 82<sup>[1]</sup>. All tiles adjacent to the modules shall be mechanically fixed in place and the fixing design shall comply with the requirements of SR 50-2<sup>[7]</sup>.

### 2.4.2 Pre-Installation Product Details

The nameplate labels are affixed to the back of each module which provide the following information:

- Product Description
  - Rated power\*
  - Rated current\*
  - Rated voltage\*
  - Open circuit voltage\*
  - Short circuit current\*
  - Weight, dimensions etc.
  - A 15-digit barcode
- (\* measured under Standard Test Conditions)

Note: The value of VOC (voltage at open circuit) times the number of modules in series shall not be greater than the maximum system voltage marked in the nameplate (1000V/1500V DC).

The roof is assessed to establish the best position and orientation of the modules. To minimise uplift caused by wind loads, modules shall not be installed within 0.5m from the edge of the roof or projection unless wind loading calculations for the specific site have been carried out.

#### 2.4.2.1 Risk assessment

Before work commences on the installation, a health and safety risk assessment must be completed and recorded by the installer in the Risk Assessment Form. Items assessed to include:

- Safe access to the roof.
- Ability of roof structure to accommodate all applied loadings.
- Working at height.
- Manual handling.
- Working in dusty/dark/confined spaces.
- Lifting of materials including cranes, teleporters and forklifts
- Working near or close to openings i.e. stair or loft openings.
- Safe access within lofts.
- Use of power tools.
- Effects of wind and snow loads.
- Fire mitigation.
- Fireman Safety
- Access for routing electrical cables.
- Protection from overhead wires.
- Any other risk associated with the installation.

Cautions to include:

- Hardware used must be compatible with the mounting material to avoid galvanic corrosion.
- Only connectors that are designed for photovoltaic systems and that match the PV modules shall be used.
- Only specialist tools, as recommended by the connector manufacturer shall be used when making electrical connectors for panel.
- The maximum number of series connected modules, which depends on system design, the type of inverter used and environmental conditions, shall not be exceeded.
- The grounding cable must be properly fastened as referenced in 2.4.1.
- As the supply from PV modules cannot be switched off, special precautions shall be made to ensure that live parts are either not accessible or cannot be touched during installation, use and maintenance.

- If the inverter is mounted in the loft it shall be within 1.5m from the DC cable point of entry. Otherwise automatic DC disconnect shall be fitted, again, within 1.5m of the DC cable entering the loft. This system of isolation shall automatically isolate the DV circuit when the AC supply is disconnected to the building.
- PV modules are current-limiting devices, which require a non-standard approach when designing fault protection systems. Fuses are not likely to operate under short-circuit conditions. DC Fuses are required when joining three or more strings of PV panels in parallel.
- If the building is deemed to require a lightning protection system (LPS), a suitably qualified lightning protection design professional shall be engaged. The advice of Heat Merchants Group shall be sought in such instances.

#### 2.4.3 Site Survey

Following completion of the initial assessment, a site survey must be carried out by the installer to determine the suitability of the property and identify any rectification required. Copies of this should be kept by the installer and the homeowner. This survey will typically cover the following points:

- Verify details from the Heat Merchants Group Quotation Enquiry Form.
- Identification of any special user requirements.
- Shade, such as that cast from trees or neighbouring buildings can have a significant impact on the performance of a system. Both the current and the future potential risk should be considered.
- Suitability of roof (is the roof structure in good condition). Any timbers showing signs of damaged or rot must be replaced.
- The buildings location, topography and orientation of the modules will have a significant effect on the power generated by the system. A south facing elevation at 35° pitch is ideal (south-east or south-west elevations can also achieve favourable results).
- The pitch of the roof is suitable for the fixing system to be used (pitch roof or flat roof mounting system).
- The pitch of the roof is less than 70°.
- If the panels are required to go on two orientations, then each orientation should be split into two separate strings.
- Annual solar radiation for different roof pitch and orientation is given in Table 3.
- Access to module location for both installation and maintenance.



- All DC cables should be installed to provide the shortest run possible. Positive and negative cables of the same string or main DC supply should be installed together, avoiding the creation of loops in the system. This requirement includes any associated earth/bonding conductors.
- A suitable location for the inverter, where possible in the loft (provided there is a safe means of access), mounted on a fireproof board which extends to a minimum of 150mm beyond the edge of the inverter, alternatively in the utility room or next to the main consumer board.

#### 2.4.4 Roof Fixings

Heat Merchants Group define the roof kit to be used, depending on the type of roof surface and pitch. Only approved SunFixings roof brackets supplied by Heat Merchants Group shall be used. These are manufactured from stainless steel and high-grade aluminium. All roof fixings specified for all pitched roofs are MCS 012<sup>[8]</sup> certified. Isolation gaskets shall be used where necessary to ensure bi-metallic corrosion does not occur.

Sunfixings Ltd. offer a software package to determine wind/snow loading and fixing requirements for individual installations (both flat and pitched roof installations).

The PV modules and fixing bracket systems are designed to cover all Irish wind zones (as illustrated in figure NA.1 in Irish National Annex to I.S. EN1991-1-4<sup>[9]</sup>). However, in high wind load areas, e.g. at excessive heights or very exposed areas, additional roof fixing brackets may be required. The advice of Heat Merchants Group shall be sought in all such instances, or if doubt exists.

Two bracket sets per PV Module are required as a minimum, dependant on the site-specific wind load analysis of the building. These brackets should be directly fixed into a timber reinforcing plants (not standard rafters or battens). See figure 2, 4 and 5 and Cl. 2.4.5.1 of this certificate. The installer shall ensure the coach screws are securely fixed to the timber reinforcing plant.

Slates / tiles at fitting locations shall be trimmed or re-worked as required to accommodate non-transference of mechanical loads due to wind deflections. See figures 6 and 7.

Heat Merchants Group use the Sunfixing Ltd. mounting system for both slate and tile pitched roofs. The slate mounting fixing is supplied with and aluminium flashing tested to MCS012<sup>[8]</sup> and suitable for roof pitches ranging from 1° to 45°. Installation of the flashing systems to be performed in accordance with the Heat Merchants Group Installation manual.

Where convenient, the cable can be run through the overlap in the underlay. Otherwise, the cable is passed through the underlay and the penetration sealed using Siga Tape (NSAI Cert. 08/0314)- see figure 9. This seals the wire penetration as required to maintain weather tightness of the roofing membrane.

SunFixings module bearing rails and clamps are used to secure PV modules to roof hooks.

#### 2.4.5 Solar PV Modules, Mounting Frame Installation

The complete procedure for the installation of the Solar PV modules and mounting frames are detailed in the Heat Merchants Group solar PV system Installation Manual.

The SunFixings PV mounting frame consists of roof hooks specified to the roof finish, aluminium horizontal profile frames, anodised middle and end clamps. The aluminium horizontal mounting profiles are fixed to the roof hooks. The roof hook has a specialised clamp that fits into a slot on the lower side of the horizontal rail and clamps shut once the screw is tightened.

The solar PV Panels are supported on upper and lower aluminium profiles as per figure 2. The PV module is fixed to the profile with the special module clamps as shown in figure 3.

##### 2.4.5.1 Timber reinforcing plant installation

Solar modules shall not be secured directly to rafter timbers and shall only be fixed via timber reinforcing plants to meet the requirements of SR 50-2<sup>[7]</sup>.

##### New build:

The main contractor shall ensure that the roof, including any support system for the PV array, is designed and constructed to comply with the relevant technical specifications for the use of structural timber: I.S. EN 1995-1-1<sup>[10]</sup>. All other relevant requirements described for retrofit installation shall also apply.

##### Retrofit installations:

An assessment of the condition of the rafter timbers and general roof condition is part of the site survey report. Any timbers showing signs of damage or rot shall be replaced.

Any timbers showing signs of damage or rot must be replaced. A single length of timber reinforcing plant (1500mm x 100mm x 75mm C24 grade timber) is installed as shown in Fig. 2, 4 and 5 to accommodate each pair of hook fittings.



Additional timber reinforcing plants can be installed as required to accommodate additional sets of fixings. The full details of the standard timber reinforcing plant design are available in Heat Merchants Group installation manual.

The basic design of the timber reinforcing plant fixing option has been load tested for suitability. Any alternative reinforcing plant fixing design shall always be checked by a Chartered Structural Engineer for suitability in relation to the applicable point loads.

Any resulting modification required to the existing roof structure, shall form part of the structural design report and sign off documentation issued by the Structural Engineer. This should be completed prior to commencement of works.

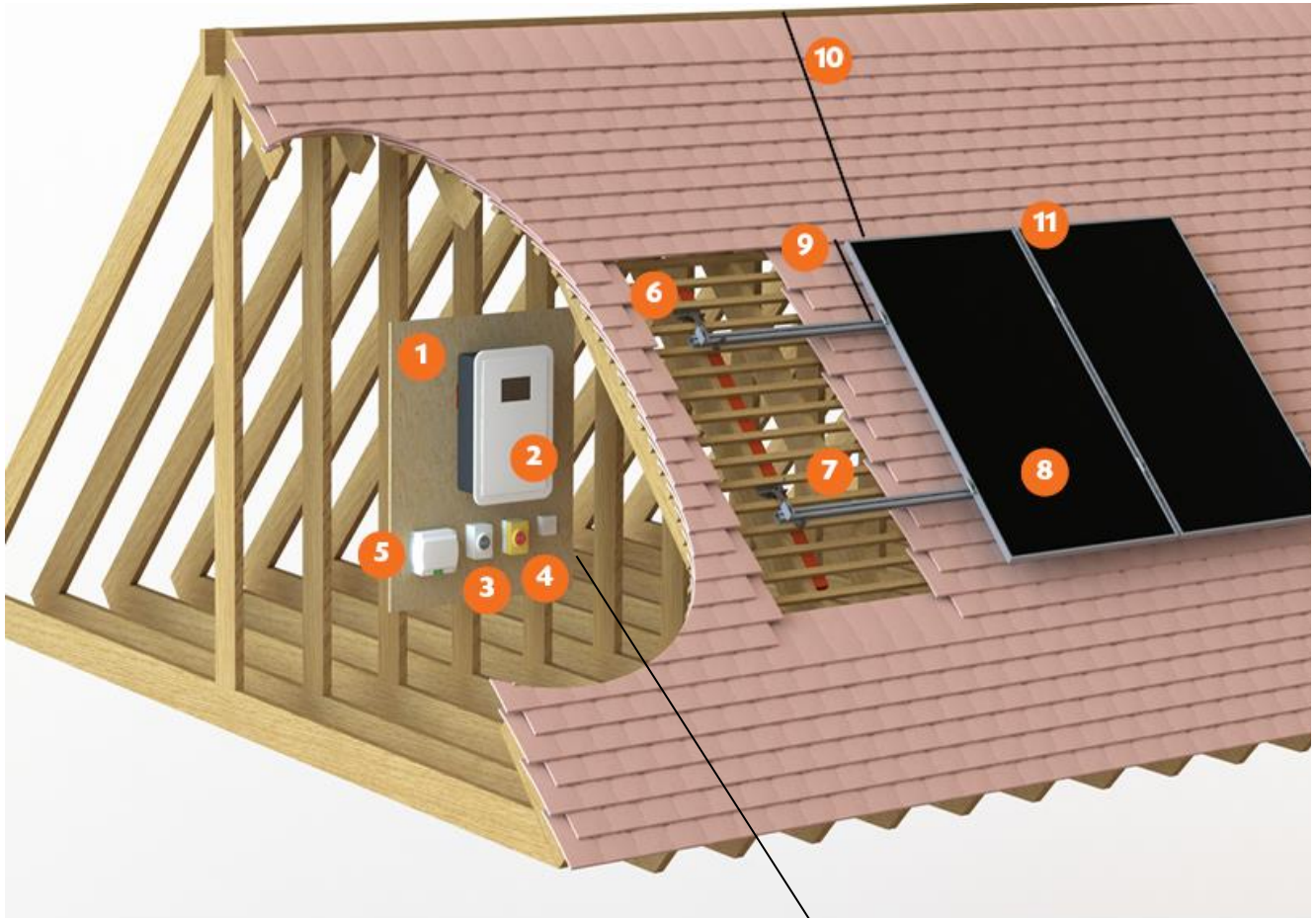

- 1- Flame retardant board
- 2- DC to AC Inverter
- 3- DC Isolator
- 4- AC Isolator
- 5- Safety Switch
- 6- Timber reinforcing plant
- 7- Roof hook
- 8- PV module
- 9- 200mm Aluminum rail offset
- 10- 500mm minimum edge offset
- 11- Minimum 20mm gap



**Figure 2: Roof fixing and inverter/electrical isolators layout**

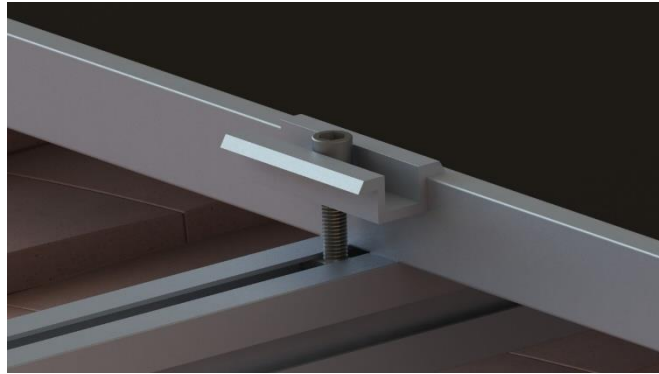

**Figure 3: Module Clamp**

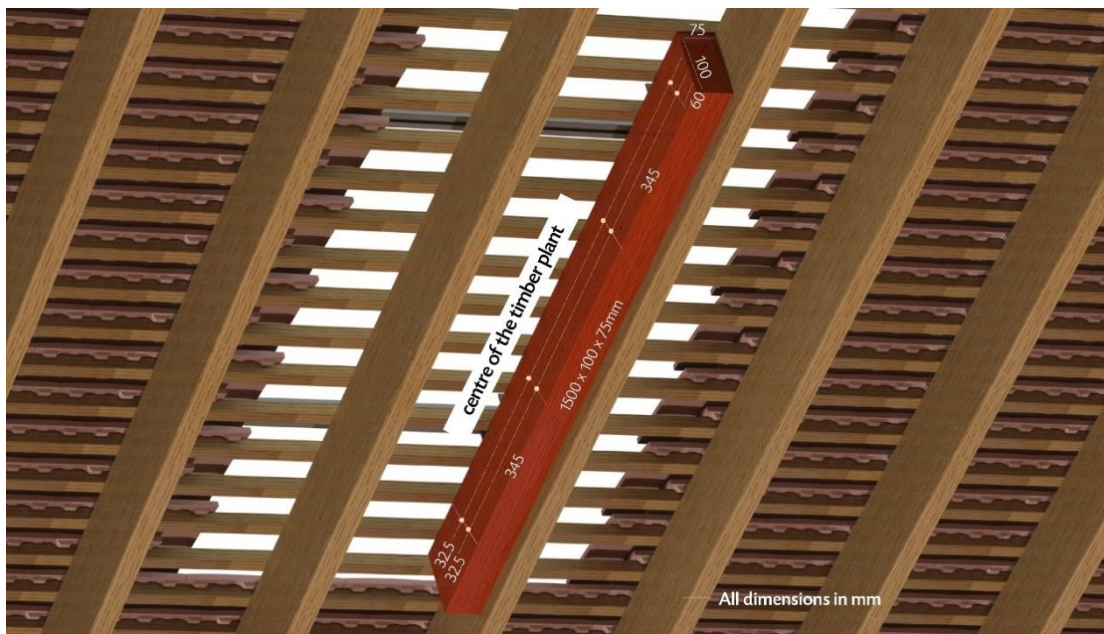

**Figure 4: Timber Reinforcement Plant Detail**

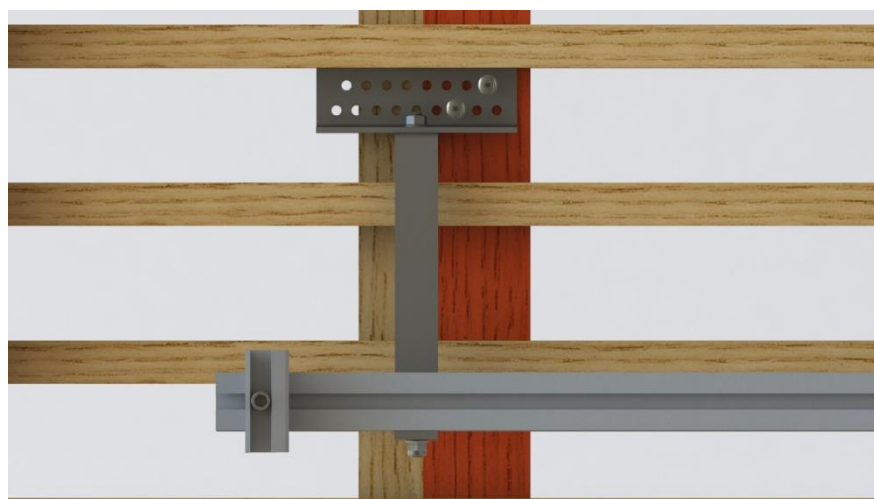

**Figure 5: Roof Hook Fixing Detail**

### 2.4.5.2 Roof Hook Fixing

Heat Merchants Group supplies the SunFixings range of MCS012<sup>[8]</sup> approved roof hook and fixings for securing the PV module mounting frame to the roof structure via the timber reinforcing plants.

The complete procedure for the installation of the solar PV roof hooks is detailed in the Heat Merchants Group Installation Manual.

The roof hook is fixed directly into the timber reinforcing plant with a minimum of two screws into predrilled 5mm holes to avoid the timber splitting.

To meet minimum loading requirements, a minimum number of two roof hooks is required per PV module. Because the hook fixing is subject to deflection under wind load which could result in tiles/slates cracking, tiles/slates should be locally notched and cut as required by the installer to accommodate the roof hooks and if required, flashing kits, however notches should not create excessive gaps, larger than those that naturally exist between tiles. Refer to figures 6 and 7 as examples of a notched tile/slate.



**Figure 6: Tile Notching**



**Figure 7: Notched Tile**

For roofs incorporated single lapped or profiled tiles (Roman, Spanish, Mission etc.), consideration shall be given to the location of the hook fitting to minimize the interference/contact between the fitting and the tile. On profiled tiles, hooks should be installed to line up with the tile trough, notching to provide clearance with the hook fixing. Heat Merchants Group use the Sunfixing Ltd. mounting system to provide a waterproof solution for both slate and tile pitched roofs.



**Figure 8: Dektite Solar Flashing**

Heat Merchants Group supplies the Dekite solar flashing (See figure 8) to carry electrical cables through the roof into the loft space.

This Dektite solar flashing is AA fire rated when tested to BS when tested to BS 476-3<sup>[11]</sup>. The solar flashing will have a design life equivalent to the solar PV modules and must be inspected as part of routine maintenance on the system.

The Dektite apron is fitted in the same way as a conventional weathering slate and positioned beneath one of the PV panels to give added protection from wind driven rain and UV light.

The DC cables pass through the flashing and then through the roof membrane, higher up the roof than the Dektite solar flashing. To facilitate the water-tight transit of the cables, they are sealed to the membrane using Siga Rissan airtight tape. See figure 9.

When the cables are installed in this manner this system creates a permanent seal which ensures the water-tightness and airtightness of the external building envelope is maintained. Airtightness tapes can be added as required to reinstate the airtightness at all service penetrations.

Where existing insulation and/or plasterboard is displaced, or there is a break in the underlay, it must be replaced with similar material and made airtight. Heat Merchants Group recommends the Siga range (NSAI Certificate 08/0314) of seals and tapes for this purpose, where required.

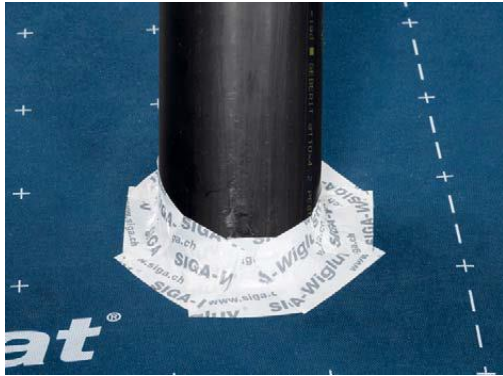

**Figure 9: Siga Tapes Sealing**

### Wiring the Solar PV system

All electrical aspects of the installation should be undertaken in accordance with ETCI regulations by a qualified Safe Electric electrical contractor.

An inverter must not be connected by means of a plug with contacts which may be live when exposed. AC cables are to be specified and installed in accordance with I.S. EN50438 [13].

The AC cable connecting the inverter(s) to the consumer unit should be sized to minimise voltage drop. The volt drop must remain within voltage drop limits as prescribed by with I.S. 10101[4].



**Figure 10: DC and AC Isolators**

The AC isolator switch shall clearly show the ON and OFF positions and be labelled as 'PV system--main AC isolator'. The DC isolator switch shall clearly show the ON and OFF positions and be labelled as 'PV system - main DC isolator'. Isolation and switching of both the AC and DC side of the installation shall also comply with the requirements of with I.S. 10101[4].

Cable protection from the inverter(s) must be provided at the distribution board. This protective measure shall be specified and installed in accordance with the requirements of IEC 60364 [14], ensuring there is no requirement for additional overcurrent protection to be installed at the inverter end of the AC installation.

All the DC component ratings (cables, isolators/disconnectors, switches, connectors, etc) of the system must be derived from the maximum voltage and current of the relevant part of the PV array. String cables must be rated as detailed in Cl. 2.4.1 of this certificate.

For every DC system, double insulation cabling must be applied as the method of shock protection. In this instance the use of suitably CE certified rated cables, connectors and enclosures along with controlled installation techniques are defined in I.S. 10101[4].

As per TGD Part B. Vol 2, Cl. 5.4.5.1, where Photovoltaic (P.V.) panels are provided on buildings, provision should be made for the isolation of the panel array externally in accordance with I.S. 10101[4].

The inverters are fitted with an anti-islanding feature (automatic disconnection of circuit) and require a live grid connection to function. Therefore, if the power is switched off at the mains, there will be no current downstream from the inverter. If the DC cable is more than 1.5 meters in length within the building, an automatic DC disconnect safety switch shall be fitted within 1.5m of the point of entry of the DC cables, this will interrupt the DC current should the mains electricity be shut off. See figure 1.

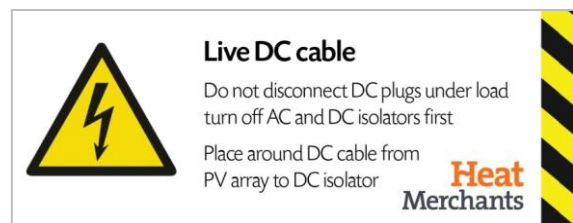

**Figure 11: DC Cable Label**

Exterior cable colour coding is not required for PV systems. PV cables are black in colour to assist in UV resistance. For all cable runs, cables shall be labelled "Live DC cable". Labels shall be fixed every 5 to 10m on straight runs, where a clear view is possible between labels. See Figure 11.

DC cables should be fitted with additional mechanical protection between the point of entry of the DC cables and the inverter location or automatic DC disconnect safety switch.

PV DC cable runs should be kept as short as practical. Where multiple PV sub-arrays and/or string conductors enter a junction box - they should be grouped or identified in pairs so that positive and negative conductors of the same circuit may easily be clearly distinguished from other pairs.

The DC junction box must be labelled as 'PV array DC junction box' and also labelled with 'Danger, contains live parts during daylight'. All labels must be clear, legible, located so as to be easily visible, and durably constructed and affixed to last the lifetime of the installation.

A PV system cannot be turned off – terminals will remain live at all times during daylight hours. It is important to ensure that anyone opening an enclosure is fully aware of this. The short-circuit protection afforded by the cable installation throughout the rest of the DC circuit needs to be maintained in the construction, and makeup of the DC junction box. (See IEC 61140 [15]).

To protect the AC system, when required, surge suppression devices may be fitted at the main incoming point of AC supply (at the consumer's cut-out). To protect the DC system, surge suppression devices can be fitted at the inverter end of the DC cabling and at the array.

An accessible means of AC isolation shall be provided in addition to the RCBO fitted in the consumer unit. The AC isolator shall be fitted adjacent to the inverter to allow for a means of isolation should the need arise for maintenance on the PV system. See figures 1 and 10.

This isolator shall be located in close proximity to the Inverter and must fulfil the following requirements/conditions:

- To switch all live and neutral lines.
- To clearly show the ON and OFF positions. They shall be labelled as 'Solar PV System – AC isolator'. See figure 12.

Short-circuit protection shall be achieved by:

- Fabrication of the enclosure from non-conductive material.
- Positive and negative bus-bars and terminals adequately separated and segregated within the enclosure and/or by a suitably sized insulating plate, or separate positive and negative junction boxes. Only DC isolators shall be used for DC lines.
- Suitably designed cable and terminal layouts to ensure that short-circuits during installation and subsequent maintenance are extremely unlikely.

The Solis string inverter contains a kWh meter and logs the daily and cumulative energy production of the PV system, which can be reviewed by the end user.

In situations where the inverter is located in the loft, a separate kWh meter may be installed in, or adjacent to the consumer unit to facilitate easy access to view the power production of the PV system.

Where there is a perceived increase in risk of direct lightning strike as a consequence of the installation of the PV system, specialists in lightning protection should be consulted with a view to installing a separate lightning protection system in accordance with I.S. EN 62305-1[5].

#### 2.4.6 Inspection and Testing – DC Side (PV Array)

The inspection and testing of the DC side of the PV system shall be performed in accordance with the requirements of BS 7671[16] and I.S. EN 62446[17].

This inspection/verification sequence includes:

- Following an inspection schedule.
- Continuity test of protective earthing and/or equipotential bonding conductors (if fitted).
- Polarity test.
- String open circuit voltage test.
- String short circuit current test.
- Functional tests.
- Insulation resistance of the DC circuits.

These tests shall be recorded by the installer in the Heat Merchants Group Solar PV Systems installation checklist and in the PV array test report documents.

Full details of the inspection schedule and guidance on test procedures are contained with I.S. EN 62446 [16].

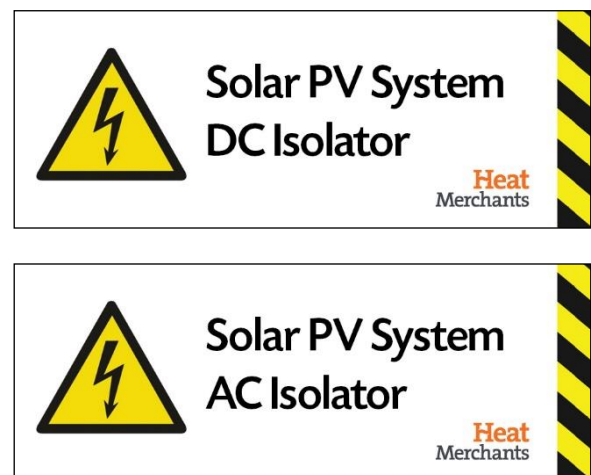

**Figure 12: Examples of Isolator Labelling**

To allow for maintenance and inspection tasks to be carried out safely, a means of isolation needs to be provided on the DC side of an inverter. The means of isolation shall:

- Be readily accessible and immediately adjacent to or incorporated into the inverter
- The DC switch must isolate all live conductors (double pole to isolate PV array positive and negative conductors).
- The switch must be rated for DC operation at the system maximum voltage.

- The DC switch must be labelled as 'PV array DC isolator', with the ON and OFF positions clearly marked. Switch enclosures must also be labelled with 'Danger - contains live parts during daylight'. All labels must be clear, easily visible and durable. During routine maintenance, labels showing signs of degradation shall be replaced.
- An additional DC switch may be specified for systems with long DC cable runs (typically at the point of cable entry into the building) – so as to provide a means of isolating the cable for safety reasons or maintenance works.

## 2.5 SYSTEM EARTHING

### 2.5.1 DC Side Earthing

As specified in IEC62548<sup>[18]</sup> there are a number of possible PV array system earthing scenarios which can be summarized as follows:

- No earth connection.
- Hardwired connection of positive or negative conductor to earth.
- Centre tapped array – with / without earth connection.
- High impedance connection of positive or negative conductor to earth (for functional reasons).

Positive and negative cables of the same string or main DC supply should be bundled together, avoiding the creation of loops in the system. This requirement includes any associated earth/bonding conductors. Long cables or DC cables run inside walls shall be installed in earthed metal conduit or trunking or be screened (armoured) cables. In addition, all panels shall be bonded in order to avoid electrical potential differences.

A number of earthing or bonding options of the PV array exist as follows:

- a) Functional earthing of conductive non-current carrying parts (e.g. to allow for better detection of leakage paths to earth). Earthing/bonding of exposed conductive parts of a PV array shall be performed in accordance with IEC 62548<sup>[18]</sup> requirements.
- b) Earthing for lightning protection.
- c) Equipotential bonding to avoid uneven potentials across an installation.
- d) Functional earthing of one current carrying pole of the PV array - functionally earthed PV array.

An earth conductor may perform one or more of these functions in an installation. The dimensions and location of the conductor are dependent on its function.

### 2.5.2 Bonding conductor size

The conductor used to earth exposed metallic frames of the PV array shall have a minimum size of 6 mm<sup>2</sup> copper or equivalent. For some system configurations, the minimum conductor size may need to be larger due to lightning system requirements.

## 2.6 INVERTER LOCATION

The string inverters specified in this certificate are air cooled passively by natural convection of air on the heat dissipation fins on the rear of the inverter. It is important that the air flow is never impeded or blocked by other components or debris by adhering to the clearance advice in the inverter installation manual.

The inverter shall also be mounted on a fire-resistant material, preferably on a concrete or masonry wall. If this option is not available, the inverter shall be mounted on a fire resistant substrate fitted between the trusses in the loft to and sized to extend a minimum of 150mm beyond the edge of the inverter. See figure 2.

To comply with the requirements of TGD B to the Irish Building Regulations a fire alarm shall be installed in the loft space where electrical installation have been installed. All installation details of the fire alarm shall comply with I.S. 3218<sup>[19]</sup>.

## 2.7 A.C CABLE PROTECTION

Protection for the cable from the inverter(s) must be provided at the distribution board. This protective measure shall be as specified and installed in accordance with the requirements of I.S. 10101<sup>[4]</sup>. Heat Merchants Group recommend that the AC side of the system shall be protected by using a suitable sized and rated RCBO in accordance with IEC 62423<sup>[22]</sup>.

## 2.8 SYSTEM PERFORMANCE

Shade makes a big impact on the performance of a PV system. Even a small degree of shading on part of an array can have a very significant impact on the overall array output. Shade is one element of system performance that can be specifically addressed during system design – by careful selection of array location, equipment selection and layout and in the electrical design (string design to minimise shade effects).

Shading from objects adjacent to the array (from vent pipes, chimneys satellite dishes, trees etc.) can have a very significant impact on the system performance. Where such shading is apparent, the array should be repositioned, or where possible, the object casting the shade should be relocated.



In Ireland the optimum orientation and tilt of an array is due south at 35°. Any deviation for this will result in a lower output as outlined in figure 13.

## **2.9 COMMISSIONING**

The commissioning, testing and inspection of the system should comply with the requirements of *IEC 62446* <sup>[17]</sup> including:

- Confirmation that all AC and DC wiring is correct and that no cable has been pinched. or damaged during installation.
- Confirmation that all AC junction boxes are correctly installed and closed.
- Performing continuity test of protective earthing and/or equipotential bonding conductors (where fitted).
- Performing a polarity test.
- Performing a string open circuit voltage test.
- Performing string short circuit test.
- Performing an insulation resistance test on the DC circuit.
- Performing an inverter Loss of Mains test.
- Recording/Log the number of PV modules.
- Recording/Log the make and model of the inverter.

### **2.9.1 Certification/Manuals/Warranty**

- The installer must complete the Commissioning Certificate which is contained in the Installation manual.
- The installer must complete the Maintenance Log and locate it in a viewable position.
- The installer shall hand over the User Manual to owners and instruct users on all aspects of the documentation and how to effectively use the solar equipment.
- Details of the Installation and Warranty conditions are located in the installation manual. The warranty cards should be completed and sent to the relevant manufacturer.

### **2.9.2 User Manual**

After commissioning, the user manual is provided to the homeowner. The user manual includes a recommended maintenance schedule, commissioning certificate, full contact details of the installer and guidance on the use of the PV system.

System installer information shall contain the following;

- A checklist of what to do in case of a system failure.
- Emergency shutdown/isolation procedures
- Maintenance and cleaning recommendations (if any).
- Considerations for any future building works related to the PV array (e.g. roof works).

- Warranty documentation for PV modules and inverters - to include starting date of warranty and period of warranty.

### **2.9.3 Decommissioning the System**

Due to the presence of AC and DC electrical power, only qualified persons should decommission a system.

When carrying out maintenance, the systems must be switched off using the installed AC and DC isolators. The maintenance pack provided by the installer to the homeowner shall be provided to those suitably qualified to perform maintenance on the PV system.

### **2.10 RETROFITTING/REPLACING**

The Heat Merchants Group range of PV Modules can be retrofitted onto existing roofs. Reference shall be made to Cl. 2.4 of this certificate and the Heat Merchants Group al installation manual for all conditions to be met.

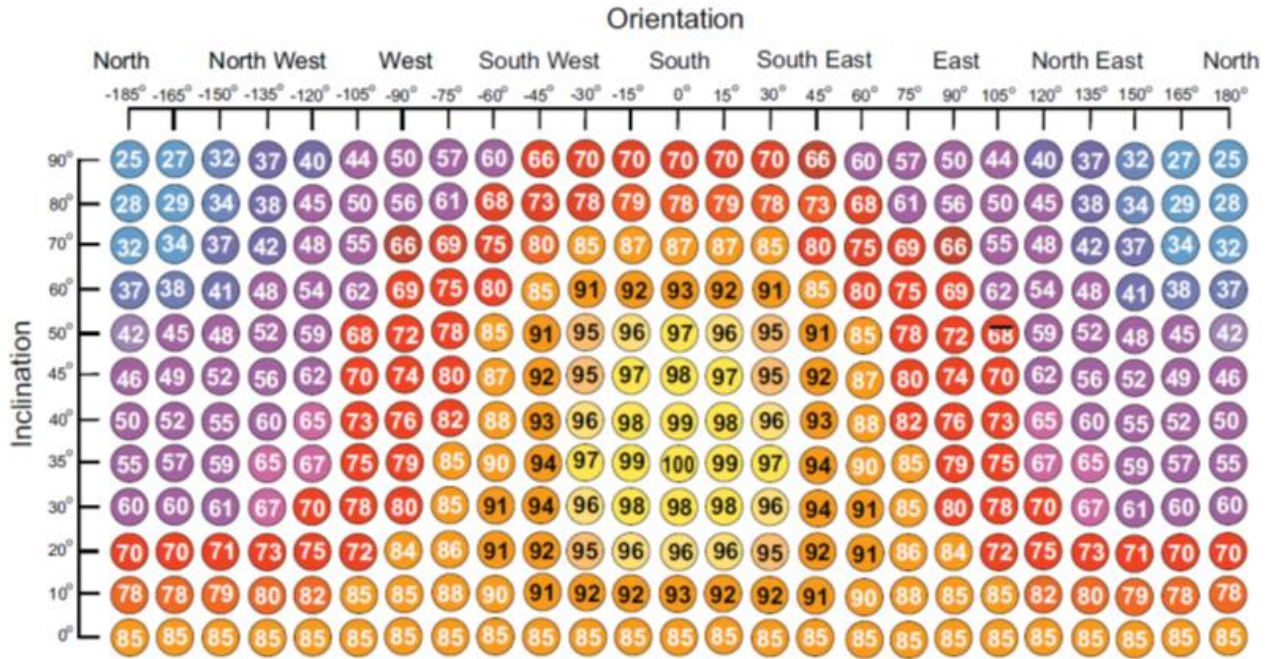

**Figure 13: Performance depending on Orientation and Inclination**

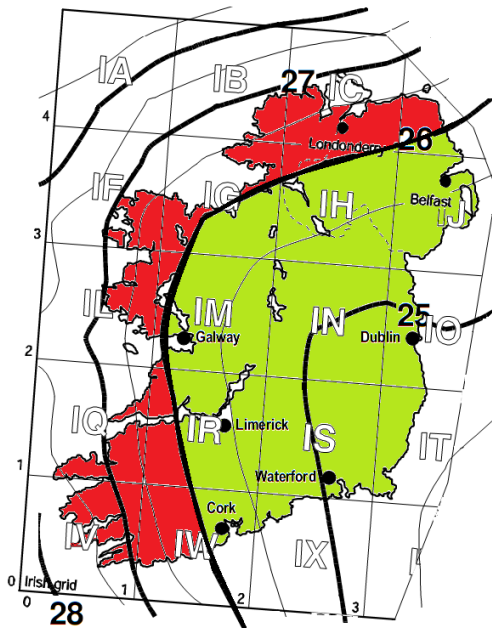

**Figure 14: Basic Wind Velocity (ref. Irish National Annex to Eurocode 1)**

### 3.1 STRENGTH AND STABILITY

When mechanical load tested in accordance with I.S. EN 61215-2<sup>[24]</sup>, the Heat Merchants Group solar PV modules achieved the maximum resistance to wind loading allowed by the standard of 5400 Pa positive pressure and 2400 Pa negative pressure without suffering any degradation in performance. Using a safety factor of 1.5 for positive pressure (S.R. 50-2<sup>[7]</sup>) and a safety factor of 2 for negative pressure, Heat Merchants Group solar PV modules, can be deemed to withstand a positive pressure of up to 3,600 Pa and a negative pressure of up to 1,200Pa.

Testing performed per Microgeneration Certification Scheme (MCS) 12<sup>[8]</sup> and EN 61215-2<sup>[24]</sup>, in conjunction with calculations performed in accordance with, I.S. EN 1990, I.S. EN 1991-1-3 and I.S. EN 1991-1-4<sup>[20]</sup>, have shown that, provided timber reinforcing plants are used as detailed in Cl. 2.4.5.1 of this certificate (see also figures 2, 4 and 5 in conjunction with Heat Merchants Group supplied roof hooks, mounting rail and module clamps, will adequately fix the panels to the pitched roof and resist the positive and negative loading.

When installed in accordance with this certificate, the fixing bracket systems incorporating timber plants and Sunfixings components should be suitable to cover all Irish wind zones (as illustrated in figure 17 NA.1 in Irish National Annex to Eurocode 1) up to an altitude of 150m. However, in wind zones 0 and 1, and in high wind load areas above 150m in altitude, at excessive heights or very exposed areas, wind loads should be calculated in accordance with I.S. EN 1991-1-4: Eurocode 1<sup>[9]</sup>. The advice of Heat Merchants Group /SunFixings shall be sought when the force acting upon the solar PV Module is calculated to be greater than the previously stated values. In such cases, Heat Merchants Group will advise on additional fixings required.

To minimise the effect of wind load on the modules, it is recommended that modules are not installed within 0.5m of the roof edge, ridge, eaves or projections such as parapets, chimneys or dormer windows.

The host roof structure and any modifications necessary to accommodate the solar PV modules should be checked by a suitably qualified engineer in accordance with the Irish Building Regulations 1997 to 2019. The main building contractor must ensure that this has been done prior to commencing installation and the timber reinforcing plant installed as detailed in CL. 2.4.5.1 of this certificate.

### 3.2 DESIGN CRITERIA AND TESTING

The electrical characteristics and performance of each of the Heat Merchants Group solar PV module designs are shown in Tables 2, however reference should be made to Cl. 2.8 of this certificate for factors that affect the efficiencies and performance of the system.

Reference should be made to Cl. 2.4 of this certificate for all aspects of wiring of the PV system, including lightning protection requirements where applicable.

The scope of testing per I.S. EN 61215<sup>[24]</sup>, is to determine the electrical and thermal characteristics of the modules and to show their capability to withstand prolonged exposure to climatic conditions.

Test Criteria	Result
Detailed inspection for visual defects	Pass
Maximum power determination	Pass
Insulation test	Pass
Measurement of temperature coefficients	Pass
Measurement of Nominal Operating Cell Temperature [NOCT, °C]	Pass
Performance at STC and NOCT	Pass
Performance at low irradiance	Pass
Outdoor exposure test	Pass
Hot spot endurance test	Pass
UV test	Pass
Thermal cycling test (200 cycles)	Pass
Humidity freeze (10 cycles)	Pass
Damp heat test 1000 hours	Pass
Robustness of terminations test	Pass
Wet leakage current test	Pass
Hail test 23m/s	Pass
Bypass diode thermal test	Pass
TÜV Rheinland Certificate No. PV 60149904	

**Table 5: Testing per I.S EN 61215<sup>[24]</sup>**

#### 4.1 BEHAVIOUR IN RELATION TO FIRE

The roof covering on which the modules are installed must have an AA, AB or AC rating as stated in Table 4.4 of TGD to Part B of the Building Regulations 1997 to 2019.

Each of the Heat Merchants Group solar PV modules have also been fire tested in accordance with I.S EN IEC 61730-2<sup>[25]</sup>. The MST 23 fire test is performed to determine the fire-resistance characteristics of the modules when exposed to a fire source originating from the outside of the building and consists of single burning brand and spread of flame tests. All modules in the Heat Merchants Group Solar PV range achieved a Class C minimum fire resistance rating.

Multi-cable fire stops must be used to effectively seal cable bunches in electrical trunking and cable trays where they pass through fire rated walls and floors to meet the requirements of TGD Part B to the Irish Building Regulations.

See Clause 2.4 of this certificate for issues related to the installation and location of the inverter and the requirement to install a fire alarm in the loft space of the building.

#### 4.2 WEATHERTIGHTNESS

The Heat Merchants Group range of PV Modules are fixed to the roof structure using roof hook fittings as described in Clause 2.4.5.24 of this certificate. By locally trimming the slate /tile to accommodate the fitting all unprotected gaps caused by the mounting and installation arrangement shall be no greater than those pre-existing before their installation. The SunFixings roof hook system has been tested in accordance with the requirements of CEN/TR 15601<sup>[26]</sup> and MCS 012<sup>[8]</sup>.

As part of their installation kit, Heat Merchants Group supplies the Dektite solar flashing for the cables from the PV panels that pass through the roof, (See figure 8). This flashing is located under the installed panels for additional protection from the elements. Refer also to Cl. 2.4.4 the use of the Sunfixing Ltd. mounting system for both slate and tile pitched roofs

Siga Airtight tape is used on the roofing felt to facilitate the water-tight transit of the wires through the felt. See figure 9. ONEY

Completed roofs will provide adequate resistance to weather ingress, when installed in accordance with this Certificate and the Heat Merchants Group installation instructions. Particular attention should be paid to correct installation of all components and to the detailing and positioning of gaskets/grommets where cables enter the building.

The Heat Merchants Group range of PV Modules have also been subjected to the weather-related tests per I.S. EN 61215<sup>[24]</sup> as listed in the Table 5 of this certificate.

#### 4.3 MAINTENANCE

All maintenance should only be carried out by a suitably qualified person approved by the Heat Merchants Group. The electrical and mechanical connections shall be periodically checked to make sure they are clean, safe, complete and secure, including the mechanical fixing to the roof structure. In the event of a problem, a suitably qualified PV design professional shall be engaged, or Heat Merchants Group shall be contacted. High-voltage gloves and glove protectors must always be worn when working on live high-voltage DC circuits. The front surface of the modules should be covered by an opaque cloth or other material before any maintenance commences on the live portion of the circuitry. Fall-protection equipment, including harnesses, safety lines, and proper anchoring systems, shall also be used.

The inverter status should also be periodically checked including, voltage levels, frequency level and current power generation levels during daylight hours, to ensure that the system is operating correctly. If any anomalies are noted, the installer/commissioner or Heat Merchants Group should be contacted.

The homeowner should be aware of any shading developing, i.e. from trees or vegetation growing in the vicinity. Shade from such vegetation can have a significant impact on the performance of a system.

Any build-up of dirt, dust, bird droppings etc., that is not washed away by rain, can also affect the performance of the modules. In such instances, the panel may require washing. Heat Merchants Group that the PV modules to be cleaned in accordance with the manufacturer's guidance. Climbing onto the roof is to be avoided and the services of a qualified professional who is trained in occupational health and safety procedures to clean the PV modules is highly recommended.

#### **4.4 DURABILITY**

The PV modules have been assessed for durability in accordance with I.S. EN 61215<sup>[2]</sup>. Heat Merchants Group warrants the power output from the PV modules to 90% of nominal after 10 years and 80% after 25 years. The terms of the warranty are outside the scope of this certificate.

The string inverters offered by Heat Merchants Group have a warranty that extends to five years and may need replacing during the design life of the solar PV system.

The structural durability of the Heat Merchants Group solar PV module, fixings, flashing, etc., has been assessed, and if maintained as per the maintenance schedule, should have a design life equivalent to that of the roof structure on which they are incorporated.

#### **4.5 END OF LIFE**

Disposal of any components must comply with the Waste Electrical and Electronic Equipment (WEEE)<sup>[27]</sup> and Restriction of Hazardous Substances (RoHS)<sup>[27]</sup> directives.

#### **4.6 OTHER INVESTIGATIONS**

- (i) Existing data on systems properties in relation to fire, electrical safety, performance, durability and the mechanical strength/stability of the PV modules and system components were assessed.
- (ii) The manufacturing process of each of the module designs were audited and examined including the methods adopted for quality control and details were obtained of the quality and composition of the materials used.
- (iii) Site visits were conducted to assess the practicability of installation as well as the history of performance in use of the product.
- (iv) An assessment was also performed on all installation control paperwork and well as training and technical support offered to installers registered with Heat Merchants Group .

## 5.0 CONDITIONS OF CERTIFICATION

**5.1** National Standards Authority of Ireland ("NSAI") following consultation with NSAI Agrément has assessed the performance and method of installation of the product/process and the quality of the materials used in its manufacture and certifies the product/process to be fit for the use for which it is certified provided that it is manufactured, installed, used and maintained in accordance with the descriptions and specifications set out in this Certificate and in accordance with the manufacturer's instructions and usual trade practice. This Certificate shall remain valid for five years from date of issue or revision date so long as:

- (a) the specification of the product is unchanged.
- (b) the Building Regulations 1997 to 2019 and any other regulation or standard applicable to the product/process, its use or installation remains unchanged.
- (c) the product continues to be assessed for the quality of its manufacture and marking by NSAI.
- (d) no new information becomes available which in the opinion of the NSAI, would preclude the granting of the Certificate.
- (e) the product or process continues to be manufactured, installed, used and maintained in accordance with the description, specifications and safety recommendations set out in this certificate.
- (f) the registration and/or surveillance fees due to NSAI Agrément are paid.

**5.2** The NSAI Agrément mark and certification number may only be used on or in relation to product/processes in respect of which a valid Certificate exists. If the Certificate becomes invalid the Certificate holder must not use the NSAI Agrément mark and certification number and must remove them from the products already marked.

**5.3** In granting Certification, the NSAI makes no representation as to;

- (a) the absence or presence of patent rights subsisting in the product/process; or
- (b) the legal right of the Certificate holder to market, install or maintain the product/process; or
- (c) whether individual products have been manufactured or installed by the Certificate holder in accordance with the descriptions and specifications set out in this Certificate.

**5.4** This Certificate does not comprise installation instructions and does not replace the manufacturer's directions or any professional or trade advice relating to use and installation which may be appropriate.

**5.5** Any recommendations contained in this Certificate relating to the safe use of the certified product/process are preconditions to the validity of the Certificate. However, the NSAI does not certify that the manufacture or installation of the certified product or process in accordance with the descriptions and specifications set out in this Certificate will satisfy the requirements of the Safety, Health and Welfare at Work Act 2005<sup>Error! Reference source not found.</sup>, or of any other current or future common law duty of care owed by the manufacturer or by the Certificate holder.

**5.6** The NSAI is not responsible to any person or body for loss or damage including personal injury arising as a direct or indirect result of the use of this product or process.

**5.7** Where reference is made in this Certificate to any Act of the Oireachtas, Regulation made thereunder, Statutory Instrument, Code of Practice, National Standards, manufacturer's instructions, or similar publication, it shall be construed as reference to such publication in the form in which it is in force at the date of this Certification.

## NSAI Agrément

This Certificate No. **21/0426** is accordingly granted by the NSAI to **Heat Merchants Group** on behalf of NSAI Agrément.

Date of Issue: **30<sup>th</sup> April 2021**

Signed

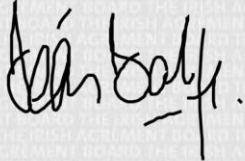

**Seán Balfe**  
**Director of NSAI Agrément**

Readers may check that the status of this Certificate has not changed by contacting NSAI Agrément, NSAI, 1 Swift Square, Northwood, Santry, Dublin 9, Ireland. Telephone: (01) 807 3800. Fax: (01) 807 3842. [www.n sai.ie](http://www.n sai.ie)



## Bibliography

- [1] SR 82:2017, *Irish code of practice – Slating and Tiling.*
- [2] I.S. EN 61215-1-1:2016: *Terrestrial photovoltaic (PV) modules - Design, qualification and type approval –Part 1-1: Special requirements for testing of crystalline silicon photovoltaic (PV) modules.*
- [3] MCS 010: Issue1.5: *Generic Factory Production Control (FPC) requirements* and MCS 005-2.3: *Product Certification requirements for Photovoltaic modules.*
- [4] I.S. 10101: 2020: *National Rules for Electrical Installations.*
- [5] EN 62305-: 2011 COR 2017: *Protection Against Lightning - Part 1: General Principles*
- [6] I.S. EN50438: 2013: *Requirements for micro-generating plants to be connected in parallel with public low-voltage distribution networks.*
- [7] SR 50-2:2012 *Code of practice for building services – Part 2: Thermal solar systems*
- [8] MCS 012: *Product Certification Scheme Requirements- Pitched Roof installation kits.*
- [9] I.S. EN 1991-1-4:2005: *Eurocode 1 – Actions on structures – General actions – Wind actions.*
- [10] I.S. EN 1995-1-1:2005 *Eurocode 5 – Design of timber structures – General – Common rules and rules for buildings.*
- [11] BS 476-3:2004 *Fire tests on building materials and structures – Classification and method of test for external fire exposure to roofs.*
- [12] Eurocode 0 – Basis of Structural Design / Eurocode 1 - *Design of Concrete Structure* /Eurocode 3 - *Design of Steel Structure* / Eurocode 5 - *Design of timber structures* / Eurocode 3– *Design of steel structures* / Eurocode 9 - *Design of aluminium structures.*
- [13] I.S. EN 50438: 2013: *Requirements for micro-generating plants to be connected in parallel with public low-voltage distribution networks.*
- [14] IEC 60364: *Electrical Installations for Buildings.*
- [15] IEC 61140 4th Edition, January 1, 2016: *Protection against electric shock – Common aspects for installations and equipment.*
- [16] BS 7671:2008+A3:2015: *Requirements for Electrical Installations. IET Wiring Regulations.*
- [17] IEC 62446:2016 *Photovoltaic (PV) systems - Requirements for testing, documentation and maintenance - Part 1: Grid connected systems - Documentation, commissioning tests and inspection.*
- [18] IEC /TS 62548: *Edition1.0. Technical Specification – Photovoltaic (PV) arrays – Design Requirements.*
- [19] I.S. 3218:2013: *Fire detection and alarm systems for buildings - System Design, installation, commissioning, servicing and maintenance*
- [20] I.S. EN 1990: 2014: *Basics of Structural Design + National Annex (2002).*
- [21] I.S. EN 1991-1-3 (2003): *Action on Structures - General Actions - Snow Loads (including National Annex).*
- [22] IEC 62423:2011: *Type F and Type B residual current operated circuit-breakers with or without integral overcurrent protection for household and similar uses.*
- [23] DEAP Manual: Version 4.2.1, September 2019:*Domestic Energy Assessment Procedure.*
- [24] I.S. EN 61215-2: 2017: *Terrestrial photovoltaic (PV) modules - Design, qualification and type approval – Part 2: Test Procedures.*
- [25] I.S. EN IEC 61730-2: 2018 & AC :2018-06: *Photovoltaic (PV Modules Safety Qualification – Part 2: Requirements for testing .*
- [26] CEN/TR 15601: *Hygrothermal Performance of Buildings – Resistance to wind driven rain of roof coverings with discontinuously laid small elements – Test Methods*
- [27] *Waste Electrical and Electronic Equipment Directive (WEEE Directive) 2012/19/EU.*
- [28] *Restriction of Hazardous Substances Directive 2002/95/EC.*