

NSAI

Agrément

IRISH AGRÉMENT BOARD CERTIFICATE NO. 12/0371

BOLIX SA
Stolarska 8
34-300 Żywiec, Poland
T: +48 33 4750600
E: export@bolix.pl
W: www.soltherm.eu/en

Soltherm External Thermal Insulation Composite Systems

NSAI Agrément (Irish Agrément Board) is designated by Government to issue European Technical Approvals.

NSAI Agrément Certificates establish proof that the certified products are '**proper materials**' suitable for their intended use under Irish site conditions, and in accordance with TGD Part D of the second schedule of the **Building Regulations 1997 and subsequent revisions**.



PRODUCT DESCRIPTION:

This Certificate relates to the Soltherm P and MW Systems. The systems comprise of:

- Surface preparation of substrate;
- Full system beads and render only beads;
- Insulation boards
 - **P System:** Expanded Polystyrene and Graphite Enhanced Polystyrene
 - **MW System:** Mineral Wool
- Cementitious base coat with reinforcement;
- Decorative finish (acrylic, mineral, silicone, silicone/acrylic, silicate, dash)
- Mechanical fixings;
- Adhesive fixings;
- Weather tight joints;
- Movement joints;
- Provision for limiting cold bridging at external wall/floor junctions in compliance with Acceptable Construction Details published by DHPLG.
- Provision for fire stopping at external compartment walls and floors.

BOLIX SA is responsible for the design, manufacture and supply of all components to approved specifications.

The system is designed by BOLIX SA/Soltherm External Insulations Ltd Agents on a project specific basis by in accordance with an approved design process.

The installation of the system is carried out by installers who have been trained by Soltherm Agents/Distributors and are approved by BOLIX SA/Soltherm External Insulations Ltd and NSAI Agrément to install the system. Applicators must adhere to strict installation guidelines as specified by BOLIX SA/Soltherm External Insulations Ltd.

In the opinion of NSAI, the Soltherm P and MW systems, as described in this Certificate, comply with the requirements of the Building Regulations.

Readers are advised to check that this Certificate has not been withdrawn or superseded by a later issue by contacting NSAI Agrément, NSAI, Santry, Dublin 9 or online at <http://www.nσαι.ie>

USE

The Soltherm P and MW systems are for the external insulation of:

- (a) Existing Concrete or masonry dwellings.
- (b) New concrete or masonry buildings, with a 30 year design life.
- (c) New Concrete or masonry commercial or industrial buildings which are designed in accordance with the Building Regulations.

The Soltherm P system is suitable for use up to a maximum of six storeys (18m) in height in purpose groups 1(a), 1(c), 1(d), 2(a), 2(b), 3, 4(a) and 4(b), and for use up to a maximum of five storeys (15 metres) in height in purpose group 1(b), as defined in TGD to Part B of the Building Regulations. The Soltherm MW system is non-combustible with a fire classification of A1 or A2-s1, d0 to IS EN 13501-1^[5] and may be used on heights in excess of this – the Certificate holder must be contacted for the specific build-up, fixing details etc.

The system has not been assessed for use with timber frame or steel frame construction. The system can be used on NSAI Agrément certified ICF (Insulated Concrete Formwork) systems.

The list of BOLIX SA/Soltherm External Insulations Ltd Agents/Distributors in Ireland is available at <https://www.soltherm.co.uk/contact>, or by contacting the certificate holder, with the as assessed list shown below,

MANUFACTURE, DESIGN & MARKETING:

The system is manufactured, designed, technically supported and marketed by:

BOLIX SA
Stolarska 8
34-300 Żywiec, Poland
T: +48 33 4750600
E: export@bolix.pl
W: www.soltherm.eu/en

The system is also designed, technically supported and marketed by:

Soltherm External Insulations Ltd,
Challenge House,
Sherwood Drive,
Bletchley Milton Keynes,
United Kingdom.
MK3 6DP

T: +44 1908 533444
E: office@soltherm.co.uk
W: www.soltherm.eu/en

Project specific design, technical support, sales and applicator approval are performed by BOLIX SA/Soltherm External Insulations Ltd or one of their approved agents/distributors.

BOLIX SA/Soltherm DISTRIBUTORS - in Republic of Ireland – ETICS system storage & supply

- PW THERMAL BUILDING SOLUTIONS LTD.
Unit 44 Third Avenue, Cookstown Industrial Estate, Tallaght, Dublin 24.
01 533 0430
info@pwthermalsolutions.com
- HAMKEL HOLDINGS LTD / SOLFIT
27 Monkstown Farm Dun Laoghaire Co. Dublin
01 2804497
info@soltherm.ie
- BLUEBUILD ENERGY LTD.
Unit 7a Block K, Ballymount Drive
Ballymount Industrial Estate
Dublin 12, D12 RT2V
01 447 0552
info@bluebuildinsulation.ie
- CASTLEFORM LTD.
Clonminam Business Park Old Knockmay Road
Portlaoise, Laois R32 DP27
+353 57 868 0684
info@castleforms.com
- GREENSPAN SYSTEM SALES IRELAND LTD.
Ballyhahill, Co. Limerick, V92 Y2C6, Ireland
+353 86 1426931
pkeenan@greenspan.ie
- RED LETTER SUPPLIES
Unit 72 Cherry Orchard Industrial Estate,
Ballyfermot Road, Dublin 10, D10 W427
+353 1 5450045
hello@red-letter.ie

1.1 ASSESSMENT

The external insulation systems included in this Certificate, which have been tested in accordance with the requirements of EAD 0400083-00-0404^[7] (ETAG 004^[6]), have been assessed against the specific requirements of the Irish Building Regulations, including method of installation, approval and training of installers, and maintenance requirements of the installed system.

In the opinion of NSAI Agrément, the Soltherm P and MW Systems, when installed by approved contractors, in accordance with this Certificate and site specific design, can meet the requirements of the Building Regulations, as indicated in Section 1.2 of this Agrément Certificate.

Part D – Materials and Workmanship**D3 – Proper Materials****D1 – Materials & Workmanship*****Part A - Structure*****A1 – Loading****A2 – Ground Movement*****Part B – Fire Safety*****B4 – External Fire Spread*****Part B Vol 2 – Fire Safety*****B9 – External Fire Spread*****Part C – Site Preparation and Resistance to Moisture*****C4 – Resistance to Weather and Ground Moisture*****Part F – Ventilation*****F2 – Condensation in Roofs*****Part J – Heat Producing Appliances*****J3 – Protection of Building*****Part L – Conservation of Fuel and Energy*****L1 – Conservation of Fuel and Energy****L2 – Conservation of Fuel and Energy**

2.1 PRODUCT DESCRIPTION

Table 1 and 2 list the full list of components of the Soltherm P and MW Systems.

The systems can be applied on a variety of existing external surfaces such as concrete, brick or rendered masonry walls. The Soltherm P render only system, as defined in Table 3 of this Certificate, can also be applied as the external render system when used in conjunction with a suitable ICF system, that have approved the use of this render system finish and who's EPS characteristics meet the minimum characteristic values as detailed in Table 3 of this certificate.

The concrete or masonry substrate on which the Soltherm P and MW Systems will be used should have a reaction to fire class A1 or A2-s1 d0 in accordance with I.S. EN 13501-1^[5].

2.2 MANUFACTURE, SUPPLY AND INSTALLATION

BOLIX SA is responsible for the design and manufacture of all components to approved specifications. BOLIX SA/Soltherm External Insulations Ltd and their approved Irish Agents/Distributors are responsible for:

- Project specific design in accordance with approved design process;
- Preliminary project assessment incorporating wind load calculations, U-value calculations, condensation risk analysis, impact resistance, substrate suitability and pull-out testing of fixings;
- Training, monitoring and review of licensed applicators in accordance with approved training and assessment procedures;
- Product supply and documentation control;
- Technical support and installation supervision;
- Sales and marketing.

The installation of Soltherm P and MW Systems is carried out by the Certificate holder's trained and approved installers in accordance with project specific specifications and method statements. Installers must also be approved and registered by NSAI Agrément under the NSAI Agrément External Thermal Insulating Composite Systems (ETICS) Approval Scheme.

2.2.1 Quality Control

The Certificate holder, and the manufacturer, operate a quality management system, and a quality plan is in place for system manufacture, system design and system installation.

2.3 DELIVERY, STORAGE AND HANDLING

The insulation is delivered to site in packs. Each pack is marked with the manufacturer's details, product identification marks and batch numbers. See Tables 1 and 2 for the designation code that must be included on the insulation identification label.

Each container for other components, e.g. mesh, renders, adhesives etc., bears the manufacturer's and the product's identification marks and batch number, and the NSAI Agrément logo incorporating the Certificate number.

Insulation should be stored on a firm, clean, dry and level base, which is off the ground. The insulation should be protected from prolonged exposure to sunlight by storing opened packs under cover in dry conditions or by re-covering with opaque polythene sheeting. Care must be taken when handling the insulation boards, to avoid damage and contact with solvents or bitumen products. The boards must not be exposed to ignition sources.

Mesh-cloth, primers, renders, paints, texture synthetic finish coatings and sealants should be stored in accordance with the manufacturer's instructions, in dry conditions, at the required storage temperatures. They should be used within the stated shelf life.

2.4 INSTALLATION

2.4.1 Approved Installers

Installation shall be carried out by BOLIX SA/Soltherm External Insulations Ltd trained applicators who are registered with NSAI Agrément.

2.4.2 General

BOLIX SA/Soltherm External Insulations Ltd or their Irish Agents/Distributors prepare a site package for each project, in accordance with the NSAI Agrément ETICS Approval Scheme. Deviations must be approved by a BOLIX SA/Soltherm External Insulations Ltd technical representative. Soltherm External Insulations Ltd or their Irish Agents/Distributors technical representatives will visit each site on a regular basis to ensure that work is carried out in accordance with the project specific site package, including the Certificate holder's installation manual. Certificates of Compliance guarantees, and homeowner's manual will be issued on successful completion of completed projects.

Mineral fibre board and lamella must be protected from moisture prior to and during installation. It may be necessary to remove and replace any unsuitable/wet material.

External works that leave the external appearance of the building inconsistent with neighbouring buildings may require planning permission. The status of this requirement should be checked with the local planning authority as required.

To maximise thermal performance, reference should be made to the requirements of Section 2 of the Acceptable Construction Details document (ACDs).

This Certificate does not contain a full set of installation instructions, but an overview of the procedures involved. For a full list of these instructions, refer to the Certificate holder's manuals. Should a conflict arise between this Certificate and the Certificate holder's manuals, this Certificate shall take precedence.

2.4.3 Site Survey and Preliminary Work

A comprehensive pre-installation site survey of the property shall be carried out in accordance with the NSAI Agrément ETICS Approval Scheme.

The substrate must be free of water repellents, dust, dirt, efflorescence and other harmful contaminants or materials that may interfere with the adhesive bond. Remove projecting mortar or concrete parts mechanically as required. Where the substrate contains dash, it must be levelled as much as possible with a layer of adhesive base coat prior to the application of the insulation boards/batts.

In retrofit applications, best practice is to cut back the existing concrete sill to minimise the effects of cold bridging. Where possible the remaining sill should be insulated over prior to the installation of the aluminium oversill as shown in Fig. 2.

Where discrepancies exist which prevent installation of the system in accordance with this Certificate and the Certificate holder's instructions, these discrepancies must be discussed with the Certificate holder and a solution implemented with the approval of the Certificate holder.

2.4.4 General

2.4.4.1 Application Procedure

The systems must be installed in accordance with the Certificate holder's instructions. Key points include:

- Weather conditions must be monitored to ensure correct application and curing conditions. Renders (adhesives, base coats, primers, finish coats) must not be applied if the temperature is below 5°C or above 25°C at the time of applications.

- In addition, the certificate holder offers the Soltherm WB basecoat that can be applied at $\geq 0^{\circ}\text{C}$ and Soltherm BC-P which can be applied at $\geq 3^{\circ}\text{C}$. Refer to the certificate holders manuals for the full set of conditions related to the application of these products. Cement-free, synthetic-resin and silicone-resin plasters must not be applied if the temperature will be below 5°C at any time during 48 hours after application; silicate plasters must not be applied if the temperature will be below 10°C at any time during 48 hours after application. When required, Soltherm 4 Seasons additive may be added to the render (Soltherm AF-P+, Soltherm SFC-P and Soltherm AFC) to the ratio of 175 ml:25 kg, blended using a spiral mixing paddle and a low-speed drill. The render must then be applied within one hour at temperatures between 2°C and 15°C and a relative humidity below 85%.
- Until fully cured, the coatings must be protected from rapid drying, precipitation, direct sunlight and strong wind.
- To avoid thermal bridging, ensure a tight adhesive free joint connection between adjacent insulation boards. Foam filler approved by the Certificate holder may be used for filling gaps up to 5mm for EPS boards – MW offcuts are used to fill gaps for MW boards. Larger gaps should be avoided, where larger gaps greater than 5mm cannot be practically avoided these gaps shall be filled with ETICS insulation material cut to size and sufficiently fixed to substrate.
- Window and door reveals should, where practicable, be insulated to minimise the effects of cold bridging in accordance with the recommendations of the Acceptable Construction Details Document published by the DHPLG, Detail 2.21, to achieve a minimum R-value of 0.6m²K/W. Ideally windows should be moved forward to the plane of the external insulation to limit the effects of thermal bridging at the reveal. Where clearance is limited, strips of approved insulation should be installed to suit available margins and details recorded as detailed in Section 4.5 of this Certificate. Best practice is to use HD EPS at these locations to meet rigidity requirements.
- Refer to the Certificate holder's instructions and the project specific site package regarding the installation method and location of the SS fixings through the reinforcing mesh where fire stops have been installed. Additional layers of mesh are also applied at these locations. Stainless steel fire fixings to be provided at a rate of one per square metre above two stories. The fixing design should take account of the extra duty required under fire conditions.

- Purpose-made powder coated aluminium windowsills are installed in accordance with the Certificate holder's instructions. These sills incorporate an insulation board fixed between them and the existing sill to limit the effects of thermal bridging. They are designed to prevent water ingress and incorporate drips to shed water clear of the system.
- All necessary post-application inspections shall be performed, and the homeowner's manual completed and handed over to the homeowner accordingly.

2.4.5 Dash Finishes

For dash finishes, the basecoat is applied over the insulation slabs, using a notched steel trowel to a thickness between 4 to 6 mm. The reinforcement mesh is applied (as per table 4 and 5) and immediately embedded into the coat, ensuring the mesh is overlapped at joints by a minimum of 100 mm. The mesh is embedded half-way in the basecoat and the surface of the basecoat is then scored with a plaster's scarifier to provide a good key for the next coat.

Soltherm SDR Dash Receiver is applied, without a primer, to a thickness between 6 and 10 mm using a stainless steel trowel. While the dash receiver is still soft, dash aggregate of the appropriate size is thrown onto the surface and, if required, lightly tapped with a timber float to ensure that a good bond is achieved. On completion, the surface must be checked to ensure an even coverage of spar dash has been achieved.

For wet dashing system, the aggregates are pre-mixed with Soltherm dash receiver. The base coat is allowed to dry. A layer of Soltherm SDR is then applied, 6-10mm, and whilst still wet, the Soltherm SDR/Chip slurry is applied. It is recommended to apply a coat of silicone paint per Table 1/2 to ensure the consistency/uniformity of the finished colour.

2.4.6 For Application to ICF Systems

For application of the Soltherm render systems onto ICF systems, the following issues must be considered. In addition reference should be made to the Soltherm installation manual for the full list of application instructions.

The Soltherm render only system may be applied to the external polystyrene insulation of ICF systems, that have been assessed and approved by Soltherm technical personnel, in accordance with the conditions of this certificate.

The designer should select a construction appropriate to the local wind-driven rain index, paying due regard to the design detailing, workmanship and materials to be used.

Before any product application can proceed, fire barriers must be fitted as required e.g. at compartment wall locations, etc. The location of all fire barriers should be agreed with the Architect/ and or a suitably qualified fire / chartered engineer. The location of fire breaks should be specified by the Architect or Fire consultant on a project specific basis.

Engineer construction and structural building design of ICF system should comply with the Building Regulations and best installation practice. This is outside the scope of Soltherm render only system.

The surface condition/finish and EPS characteristics of ICF system must be thoroughly inspected to ensure it meets all technical surface finish requirements. The surface must be stable, sound, dry, clean of surface contaminants such as dust, grease, form oils, bitumen, salts and other barrier materials that may affect adhesion like organic growth and chemical deposits.(algae, fungi). The substrate must be even and provide a plane surface.

In the case of gaps or cavities in insulation panels it is recommended to fill them with low-pressure polyurethane foam e.g. SOLTHERM PM-L. The excess of PU foam, after curing, should be removed with a knife to flush the filled gaps with a surface of the insulation panels.

Where approved by the ICF system manufacturer, it is recommended that the outer surfaces of the EPS insulation panels, are lightly rasped with coarse sandpaper or an abrasive float rasp for EPS, to remove dust from the EPS surfaces.

Where the insulation panels have grooves on the outer surface, a levelling coat shall be applied using Soltherm basecoat to plane and smooth the surface grooves and irregularities prior to standard basecoat application.

Prior to a continuous base coat application, all system specific details must be executed as per project specification or Certificate's holder instruction:

- PVC Corner beads
- PVC window protection beads
- Reinforcing stress patches
- Movement joints and beads

After initial drying of levelling coat, the standard basecoat shall be prepared and applied over the levelling coat, using a notched steel trowel to a thickness between 3 and 4 mm. The standard SOLTHERM glass fibre reinforcing mesh is applied and is immediately embedded into the coat.



The mesh must be overlapped at joints by a minimum coverage of 100 mm. The overall basecoat must be between 3-5mm, which may be achieved by the application of an additional basecoat/ slurry coat to achieve a smooth finish for the application of the finishing coats.

The external finish coats are then applied as per the standard ETICS application instructions detailed in this certificate.

	Table 1 – Soltherm P EPS-Based External Insulation Systems	Thickness (mm)	Coverage (kg/m²)
Adhesives	Soltherm SA - adhesive for EPS Soltherm UB - universal adhesive/base coat Soltherm UB special – universal adhesive/base coat Soltherm WB – winter universal adhesive/base coat Soltherm BC-P - premium microfibre reinforced adhesive/base coat		4.0 4.0 4.0 4.0 4.0
ETICS Insulation	EPS-EN 13163 ^[10] -T1-L2-W2-S5-P5-DS(N)2-DS(70,-)1-DS(70,-)2-TR100-TR150 Flame Retardant. XPS below DPC (and below ground level, where possible) per I.S. EN 13164 ^[8] . EPS UHD 200 may also be used.	20-250	
Anchors	Anchors covered by ETA's issued according of ETAG 014 can be used provided they meet the following requirements: Plate diameter ≥ 60mm and Plate stiffness ≥ 0.4kN/mm		
Base coats	Soltherm UB - universal adhesive/base coat Soltherm UB special – universal adhesive/base coat Soltherm WB - winter universal adhesive/base coat Soltherm BC-P - premium microfibre reinforced adhesive/base coat Soltherm BC-P Quick – premium microfibre reinforced white basecoat	3.0 – 5.0 (single mesh) 4.0 – 6.0 (double mesh & for dash)	~4.0 – 6.5 ~4.0 – 6.5 ~4.0 – 6.5 ~4.0 – 6.5 ~4.0 – 6.5
Glass fibre meshes	Soltherm HD 145/S Soltherm HD 158/S Soltherm HD 160/S Soltherm HD 174/S Soltherm HD 335/P		
Primers	Soltherm AP colour – mineral and acrylic renders primer Soltherm STP – silicate paints primer Soltherm STP colour - coloured primer for silicate renders Soltherm SNP – silicone paints primer Soltherm SNP colour - coloured primer for silicone renders Soltherm SP – acrylic paint primer		0.25-0.40 0.10-0.20 0.25-0.40 0.10-0.20 0.25-0.40 0.10-0.20
Finishing coats (renders)	<u>Acrylic plasters:</u> Soltherm AFC 20 – sprayed or floated acrylic finish, granulation 2mm (regular texture) Soltherm AFC 15 - sprayed or floated acrylic finish, granulation 1.5mm (regular texture) Soltherm AFC 10 - sprayed or floated acrylic finish, granulation 1mm (regular texture) Soltherm AFC 25wt – floated acrylic finish, granulation 2.5mm (woodworm texture) Soltherm AFC 15wt – floated acrylic finish, granulation 1.5mm (woodworm texture) Soltherm AFC i – floated acrylic finish, granulation 2.5mm (irregular texture) Soltherm AMC – floated acrylic mosaic plaster, granulation 0.5-2.0mm (regular texture) Soltherm AFC s – sprayed acrylic finish, granulation 1.0mm (regular finish) <u>Acrylic plasters with anti-microbiological protection:</u> Soltherm AFC 20 eco-shield – sprayed or floated biocide acrylic finish, granulation 2mm (regular texture) Soltherm AFC 15 eco-shield – sprayed or floated biocide acrylic finish, granulation 1.5mm (regular texture) Soltherm AFC 10 eco-shield – sprayed or floated biocide acrylic finish, granulation 1mm (regular texture) Soltherm AFC 25wt eco-shield – floated biocide acrylic finish, granulation 2.5mm (woodworm texture) Soltherm AFC 15wt eco-shield – floated biocide acrylic finish, granulation 1.5mm (woodworm texture) Soltherm AFC i eco-shield – floated biocide acrylic finish, granulation 2.5mm (irregular texture) Soltherm AFC s eco-shield – sprayed biocide acrylic finish, granulation 1.0mm (regular finish)	Regulated by particle size.	2.8-3.4 2.2-2.8 1.7-2.2 3.0-3.5 2.0-2.5 3.0-3.5 2.0-4.0 3.0-3.5 2.8-3.4 2.2-2.8 1.7-2.2 3.0-3.5 2.0-2.5 3.0-3.5 3.0-3.5

Table 1 Continued	<u>Mineral plasters:</u> Soltherm MTC 10 – floated mineral finish coat, granulation 1.0mm (regular texture)	Regulated by particle size	1.4-1.8
	Soltherm MTC 15 – floated mineral finish coat, granulation 1.5mm (regular texture)		2.0-2.7
	Soltherm MTC 15g – floated mineral finish coat, granulation 1.5mm (regular texture)		2.0-2.7
	Soltherm MTC 20 - floated mineral finish coat, granulation 2.0mm (regular texture)		2.5-3.2
	Soltherm MTC 30 - floated mineral finish coat, granulation 3.0mm (regular texture)		3.2-4.0
	Soltherm MTC 25wt – floated mineral finish coat, granulation 2.5mm (woodworm texture)		3.0-3.5
	Soltherm MTC 25wt g - floated mineral finish coat, granulation 2.5mm (woodworm texture)		3.0-3.5
	<u>Silicone plasters:</u> Soltherm SFC-P 10/Soltherm SFC-P 10 eco-shield – floated silicone finish, granulation 1.0mm (regular texture)		1.7-2.2
	Soltherm SFC-P 15/Soltherm SFC-P 15 eco-shield - floated silicone finish, granulation 1.5mm (regular texture)		2.2-2.8
	Soltherm SFC-P 20/Soltherm SFC-P 20 eco-shield - floated silicone finish, granulation 2.0mm (regular texture)		2.8-3.4
	Soltherm SFC-P 25wt - floated silicone finish, granulation 2.5mm (woodworm texture)		3.0-3.5
	Soltherm SFC-P+15- floated silicone finish HD, granulation 1.5mm (regular texture)		2.2-2.8
	<u>Silicate plasters:</u> Soltherm STF 10 – floated silicate finish, granulation 1.0mm (regular texture)		2.0-2.5
	Soltherm STF 15 – floated silicate finish, granulation 1.5mm (regular texture)		2.5-3.0
	Soltherm STF 20 – floated silicate finish, granulation 2.0mm (regular texture)		3.0-3.5
	Soltherm STF 25wt - floated silicate finish, granulation 2.5mm (woodworm texture)		3.0-3.5
	<u>Silicate-silicone plasters:</u> Soltherm AF-P + 15 - floated or sprayed silicate-silicone finish, granulation 1.5mm (regular texture)		2.2-2.8
	Soltherm AF-P + 20 - floated or sprayed silicate-silicone finish, granulation 2.0mm (regular texture)		2.8-3.4
	Soltherm AF-P + 25wt - floated silicate-silicone finish, granulation 2.5mm (woodworm texture)		3.0-3.5
	Soltherm AF-P + 30 – floated or sprayed silicate-silicone finish, granulation 3.0mm (regular texture)		4.0-4.8
Soltherm Dash Receiver (Soltherm SDR) – receiver coat for dash stones	9.0-15.0		
Top coats* (optional)	<u>Acrylic top coats:</u> Soltherm ACP – acrylic top coat		s.s: 0.12-0.28 l/m ² r.s: 0.18-0.40 l/m ²
	Soltherm ACP eco-shield – acrylic top coat with antimicrobial protection		s.s: 0.12-0.18 l/m ² r.s: 0.18-0.40 l/m ²
	<u>Silicate top coats:</u> Soltherm STPT –vapour permeable silicate top coat		s.s: 0.12-0.18 l/m ² r.s: 0.18-0.40 l/m ²
	<u>Silicone top coats:</u> Soltherm STC-P – vapour permeable silicone top coat		s.s: 0.18-0.28 l/m ² r.s: 0.18-0.40 l/m ²
	Soltherm STC-P eco-shield – vapour permeable silicone top coat with antimicrobial protection		s.s: 0.18-0.28 l/m ² r.s: 0.18-0.40 l/m ²
	Soltherm STC-P+ –HD silicone top coat with droplet effect		s.s: 0.12-0.18 l/m ² r.s: 0.18-0.40 l/m ²

Accessories	<p>Beads: Window reveal bead with sealing tape 2.6m Drip edge profile with mesh 2.5m PVC corner bead with mesh 100x100 2.5m PVC corner bead with mesh 100x150 2.5m PVC corner bead with mesh 80x120 2.5m Corner bead with nose 2.5m Movement joint bead for flat surfaces Movement joint bead for inner corners Clip on drip bead with mesh Trimming window profile with removable leg 2.4m 3mm stop bead 2m 3mm stop bead 2.5m 6mm stop bead 2m 6mm stop bead 2.5m 10mm stop bead 2m 10mm stop bead 2.5m 15mm stop bead 2m 15mm stop bead 2.5m Archway corner bead 2.5m Sill and reveal connection profile 2m Window sill profile 2m (best practice minimum gauge of 3-3.5mm) Movement bead 2.5m PVC groove bead with mesh 10mm x 10mm 3m PVC groove bead with mesh 20mm x 20mm 3m PVC groove bead with mesh 30mm x 20mm 3m PVC groove bead with mesh 50mm x 20mm 3m Groove bead connector 10mm Groove bead connector 20mm Groove bead connector 30mm Groove bead connector 50mm or any other ancillary item that are approved by the ETICS system manufacture such as fungicidal wash, substrate primers, additives etc</p> <p>Ancillary materials, must be approved by the Certificate holder, and are outside the scope of this certificate.</p>		
<p>* smooth surface – s.s, rough surface – r.s † S – Single mesh layer ‡ D – Double mesh layer</p>			

Table 1: Soltherm P Component Specification

Table 2 – Soltherm MW – Mineral Wool Based External Insulation System		Thickness (mm)	Coverage (kg/m²)
Adhesives	Soltherm MB – mineral wool adhesive/base coat Soltherm MA – mineral wool adhesive Soltherm UB special – universal adhesive/base coat		
Insulation	MW-EN13162 ^[9] -T5-DS(70,-)-DS(70,90)-WS-WL(P)-TR10 & TR80 (Lamella, shear strength 0.02MPa, shear modulus 1MPa) Euroclass A1, max density 130 kg/m ³ XPS below DPC (and below ground level, where possible) per I.S. EN 13164 ^[8] . EPS UHD 200 may also be used.	50-300	
Anchors	Anchors covered by ETA's issued according of ETAG 014 can be used provided they meet the following requirements: Plate diameter ≥ 60mm and Plate stiffness ≥ 0.4kN/mm		
Base coats	Soltherm MB – mineral wool adhesive/base coat Soltherm UB special – universal adhesive/base coat	3.0 – 5.0 (single mesh) 4.0 – 6.0 (double mesh & for dash)	~4.0 – 6.5
Glass fibre meshes	Soltherm HD 145/S Soltherm HD 158/S Soltherm HD 160/S Soltherm HD 174/S		
Primers	Soltherm AP colour – mineral and acrylic renders primer Soltherm STP – silicate paints primer Soltherm STP colour - coloured primer for silicate renders Soltherm SNP – silicone paints primer Soltherm SNP colour - coloured primer for silicone renders		0.25-0.40 0.10-0.20 0.25-0.40 0.10-0.20 0.25-0.40
Finishing coats (renders)	<u>Mineral plasters:</u> Soltherm MTC 10 – floated mineral finish coat, granulation 1.0mm (regular texture) Soltherm MTC 15 – floated mineral finish coat, granulation 1.5mm (regular texture) Soltherm MTC 20 – floated mineral finish coat, granulation 2.0mm (regular texture) Soltherm MTC 30 – floated mineral finish coat, granulation 3.0mm (regular texture) Soltherm MTC 25 wt – floated mineral finish coat, granulation 2.5mm (woodworm texture) <u>Silicone plasters:</u> Soltherm SFC-P 10/Soltherm SFC-P 10 eco-shield – floated silicone finish, granulation 1.0mm (regular texture) Soltherm SFC-P 15/Soltherm SFC-P 15 eco-shield - floated silicone finish, granulation 1.5mm (regular texture) Soltherm SFC-P 20/Soltherm SFC-P 20 eco-shield - floated silicone finish, granulation 2.0mm (regular texture) Soltherm SFC-P 25wt - floated silicone finish, granulation 2.5mm (woodworm texture) Soltherm SFC-P+ 15 – floated silicone finish HD, granulation 1.5mm (regular texture) Soltherm SFC-P+ 20 – floated silicone finish HD, granulation 2.0mm (regular texture)		1.4-1.8 (powder) 2.0-2.7 (powder) 2.5-3.2 (powder) 3.2-4.0 (powder) 3.0-3.5 (powder) 1.7-2.2 2.2-2.8 2.8-3.4 3.0-3.5 2.2-2.8 3.0-3.5

Finishing coats (renders)	<u>Silicate plasters:</u> Soltherm STF 10 - floated silicate finish, granulation 1.0mm (regular texture), Soltherm STF 15 - floated silicate finish, granulation 1.5mm (regular texture), Soltherm STF 20 - floated silicate finish, granulation 2.0mm (regular texture), Soltherm STF 25wt - floated silicate finish, granulation 2.5mm (woodworm texture)		2.0-2.5 2.5-3.0 3.0-3.5 3.0-3.5
	<u>Silicate-silicone plasters:</u> Soltherm AF-P+ 15 – floated or sprayed silicate-silicone finish, granulation 1.5mm (regular texture) Soltherm AF-P+ 20 – floated or sprayed silicate-silicone finish, granulation 2.0mm (regular texture) Soltherm AF-P+ 30 – floated or sprayed silicate-silicone finish, granulation 3.0mm (regular texture) Soltherm Dash Receiver (Soltherm SDR) – receiver coat for dash stones		2.2-2.8 2.8-3.4 4.0-4.8 9.0-15.0
Top coats* (optional)	<u>Silicate top coats:</u> Soltherm STPT – vapour permeable silicate top coat,		s.s: 0.12-0.18 l/m ² r.s: 0.18-0.40 l/m ²
	<u>Silicone top coats:</u> Soltherm STC-P/Soltherm STC-P eco-shield – vapour permeable silicone top coat, Soltherm STC-P+ - HD silicone top coat with droplet effect.		s.s: 0.12-0.18 l/m ² r.s: 0.18-0.40 l/m ² s.s: 0.12-0.18 l/m ² r.s: 0.18-0.40 l/m ²
Accessories	<u>Beads:</u> Window reveal bead with sealing tape 2.6m Drip edge profile with mesh 2.5m PVC corner bead with mesh 100x100 2.5m PVC corner bead with mesh 100x150 2.5m PVC corner bead with mesh 80x120 2.5m Corner bead with nose 2.5m Movement joint bead for flat surfaces Movement joint bead for inner corners Clip on drip bead with mesh Trimming window profile with removable leg 2.4m 3mm stop bead 2m 3mm stop bead 2.5m 6mm stop bead 2m 6mm stop bead 2.5m 10mm stop bead 2m 10mm stop bead 2.5m 15mm stop bead 2m 15mm stop bead 2.5m Archway corner bead 2.5m Sill and reveal connection profile 2m Window sill profile 2m (best practice minimum gauge of 3-3.5mm) Movement bead 2.5m PVC groove bead with mesh 10mm x 10mm 3m PVC groove bead with mesh 20mm x 20mm 3m PVC groove bead with mesh 30mm x 20mm 3m PVC groove bead with mesh 50mm x 20mm 3m Groove bead connector 10mm Groove bead connector 20mm Groove bead connector 30mm Groove bead connector 50mm or any other ancillary item that are approved by the ETICS system manufacture such as fungicidal wash, substrate primers, additives etc Ancillary materials, must be approved by the Certificate holder, and are outside the scope of this certificate.		

* smooth surface – s.s, rough surface – r.s

Table 2: Soltherm MW Component Specification

	Table 3 – Soltherm P ICF Render only system	Thickness (mm)	Coverage (kg/m²)
ICF Insulation	EPS-EN 13163 ^[10] -T1-L3-W2-S5-P5-DS(N)5- CS (10) 150- BS 200-WL(T)i 4.0% Fire Classification Class E	As per ICF System Design	-
Base coats	Soltherm UB - universal adhesive/base coat Soltherm UB special – universal adhesive/base coat Soltherm BC-P Quick – premium microfibre reinforced white basecoat	3.0 – 5.0 (single mesh) 4.0 – 6.0 (double mesh & for dash)	~4.0 – 6.5 ~4.0 – 6.5 ~4.0 – 6.5
Glass fibre meshes	Soltherm HD 145/S Soltherm HD 158/S Soltherm HD 160/S Soltherm HD 174/S Soltherm HD 335/P		
Primers	Soltherm AP colour – acrylic renders primer Soltherm SNP – silicone paints primer Soltherm SNP colour - coloured primer for silicone renders Soltherm SP – acrylic paint primer		0.25-0.40 0.10-0.20 0.25-0.40 0.10-0.20
Finishing coats (renders)	<u>Acrylic plasters:</u> Soltherm AFC 20 – sprayed or floated acrylic finish, granulation 2mm (regular texture) Soltherm AFC 15 - sprayed or floated acrylic finish, granulation 1.5mm (regular texture) Soltherm AFC 10 - sprayed or floated acrylic finish, granulation 1mm (regular texture) Soltherm AFC 25wt – floated acrylic finish, granulation 2.5mm (woodworm texture) Soltherm AFC 15wt – floated acrylic finish, granulation 1.5mm (woodworm texture) Soltherm AFC i – floated acrylic finish, granulation 2.5mm (irregular texture) Soltherm AMC – floated acrylic mosaic plaster, granulation 0.5-2.0mm (regular texture) Soltherm AFC s – sprayed acrylic finish, granulation 1.0mm (regular finish) <u>Acrylic plasters with anti-microbiological protection:</u> Soltherm AFC 20 eco-shield – sprayed or floated biocide acrylic finish, granulation 2mm (regular texture) Soltherm AFC 15 eco-shield – sprayed or floated biocide acrylic finish, granulation 1.5mm (regular texture) Soltherm AFC 10 eco-shield – sprayed or floated biocide acrylic finish, granulation 1mm (regular texture) Soltherm AFC 25wt eco-shield – floated biocide acrylic finish, granulation 2.5mm (woodworm texture) Soltherm AFC 15wt eco-shield – floated biocide acrylic finish, granulation 1.5mm (woodworm texture) Soltherm AFC i eco-shield – floated biocide acrylic finish, granulation 2.5mm (irregular texture) Soltherm AFC s eco-shield – sprayed biocide acrylic finish, granulation 1.0mm (regular finish) <u>Silicone plasters:</u> Soltherm SFC-P 10/Soltherm SFC-P 10 eco-shield – floated silicone finish, granulation 1.0mm (regular texture) Soltherm SFC-P 15/Soltherm SFC-P 15 eco-shield - floated silicone finish, granulation 1.5mm (regular texture) Soltherm SFC-P 20/Soltherm SFC-P 20 eco-shield - floated silicone finish, granulation 2.0mm (regular texture) Soltherm SFC-P 25wt - floated silicone finish, granulation 2.5mm (woodworm texture) Soltherm SFC-P+15- floated silicone finish HD, granulation 1.5mm (regular texture)	Regulated by particle size.	2.8-3.4 2.2-2.8 1.7-2.2 3.0-3.5 2.0-2.5 3.0-3.5 2.0-4.0 3.0-3.5 2.8-3.4 2.2-2.8 1.7-2.2 3.0-3.5 2.0-2.5 3.0-3.5 3.0-3.5 1.7-2.2 2.2-2.8 2.8-3.4 3.0-3.5 2.2-2.8

	<u>Silicate-silicone plasters:</u> Soltherm AF-P + 15 - floated or sprayed silicate-silicone finish, granulation 1.5mm (regular texture) Soltherm AF-P + 20 - floated or sprayed silicate-silicone finish, granulation 2.0mm (regular texture) Soltherm AF-P + 25wt - floated silicate-silicone finish, granulation 2.5mm (woodworm texture) Soltherm AF-P + 30 - floated or sprayed silicate-silicone finish, granulation 3.0mm (regular texture)	Regulated by particle size	2.2-2.8 2.8-3.4 3.0-3.5 4.0-4.8
Top coats* (optional)	<u>Acrylic top coats:</u> Soltherm ACP – acrylic top coat		s.s: 0.12-0.28 l/m ² r.s: 0.18-0.40 l/m ²
	Soltherm ACP eco-shield – acrylic top coat with antimicrobial protection		s.s: 0.12-0.18 l/m ² r.s: 0.18-0.40 l/m ²
	<u>Silicone top coats:</u> Soltherm STC-P – vapour permeable silicone top coat		s.s: 0.18-0.28 l/m ² r.s: 0.18-0.40 l/m ²
	Soltherm STC-P eco-shield – vapour permeable silicone top coat with antimicrobial protection		s.s: 0.18-0.28 l/m ² r.s: 0.18-0.40 l/m ²
	Soltherm STC-P+ –HD silicone top coat with droplet effect		s.s: 0.12-0.18 l/m ² r.s: 0.18-0.40 l/m ²
Accessories	See table 1		
	Ancillary materials, must be approved by the Certificate holder, and are outside the scope of this certificate.		
* smooth surface – s.s, rough surface – r.s † S – Single mesh layer ‡ D – Double mesh layer			

Table 3: Soltherm P ICF Rener only system

Note: EPS insulation is shown in the following details for illustrative purposes only. Full installation details for both Soltherm P and Soltherm MW Systems can be obtained from the certificate holder.

EPS and MW boards are bonded to the wall by applying the adhesive to the boards using the strip and dot method or full surface application using a notched trowel

Suitably prepared substrate

Double layer of mesh as required to satisfy Impact Category requirements. See tables 1 and 3.

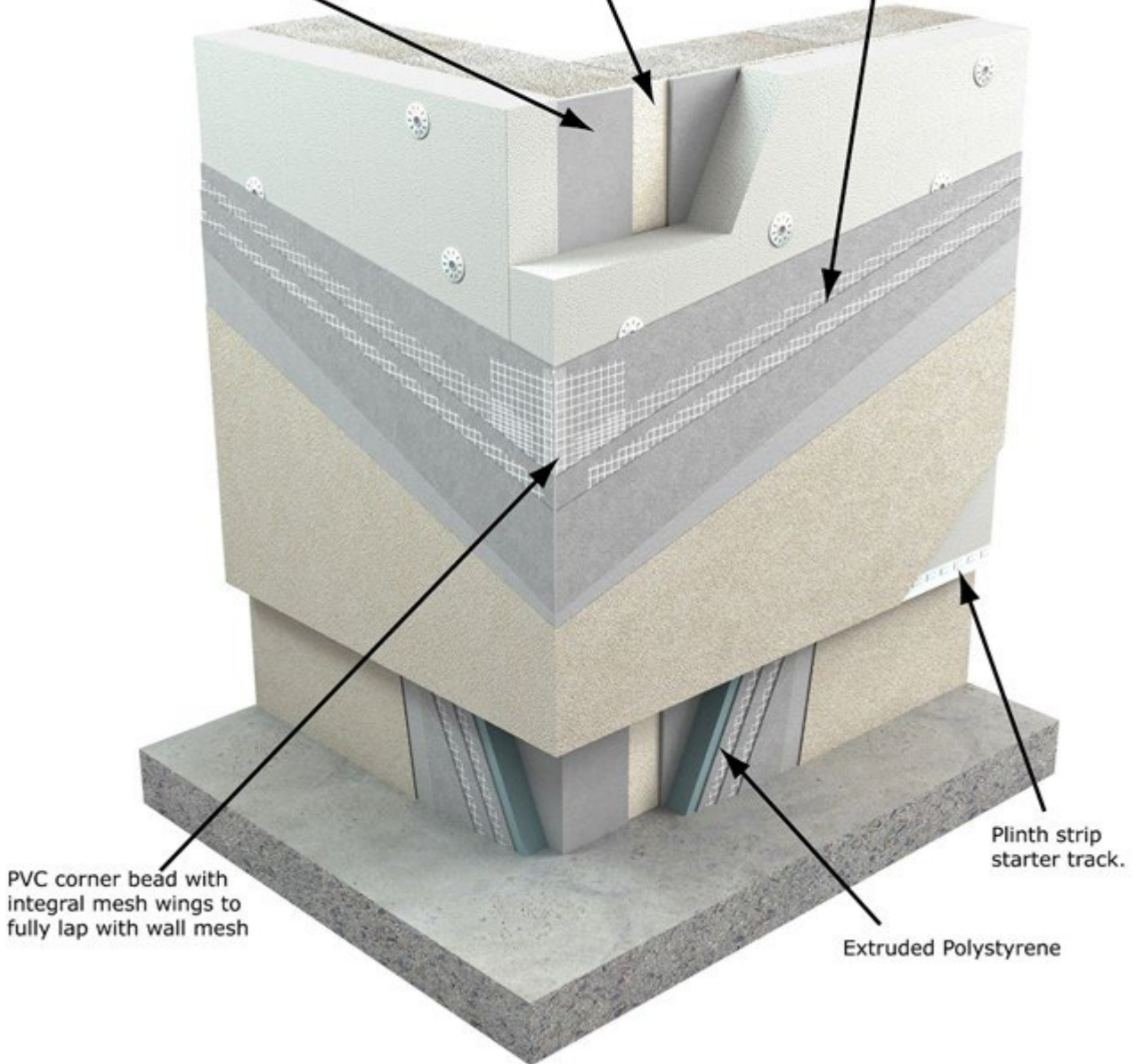

Figure 1: Corner/Plinth/Wall Details

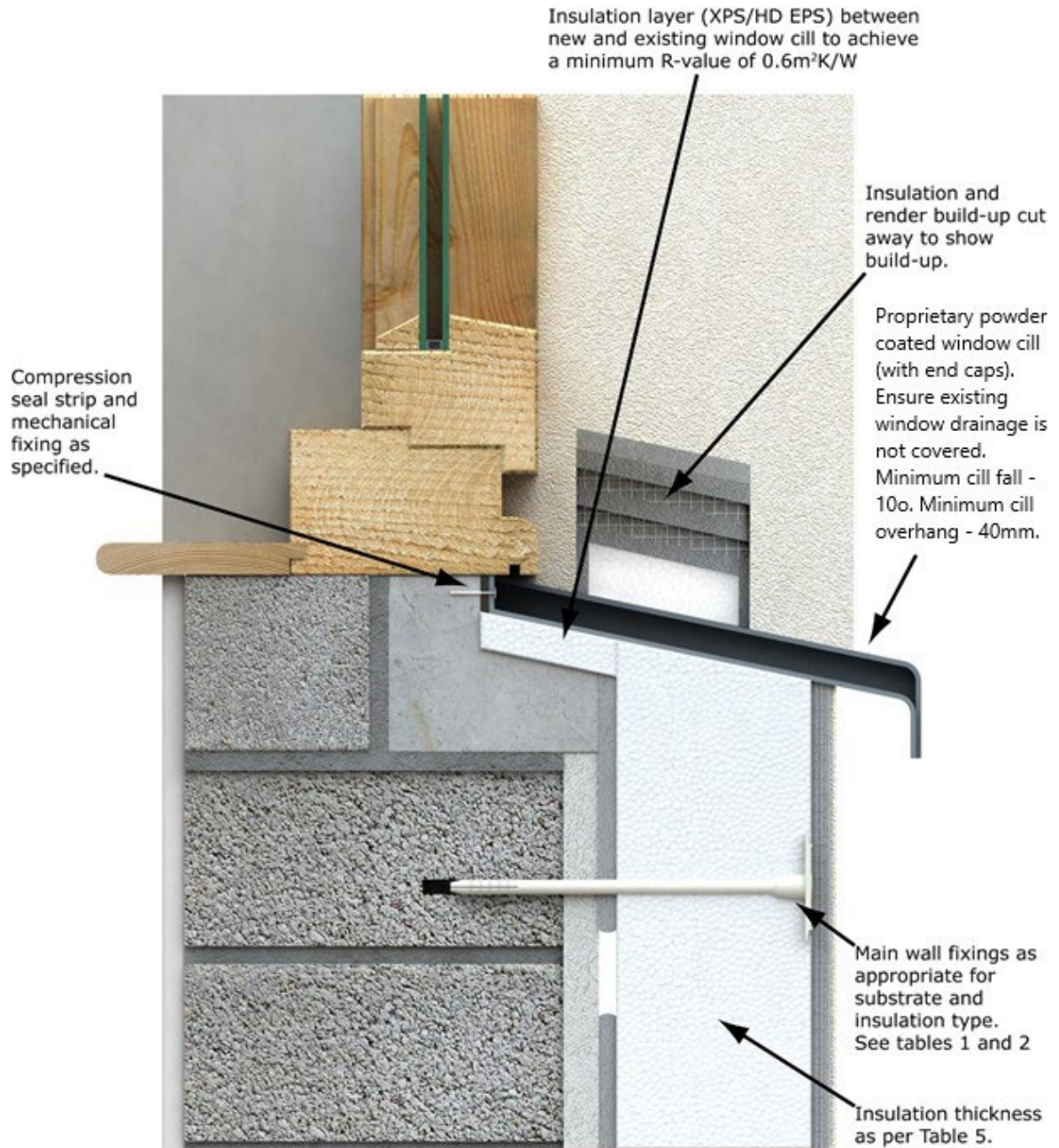

Figure 2: Window Sill Detail

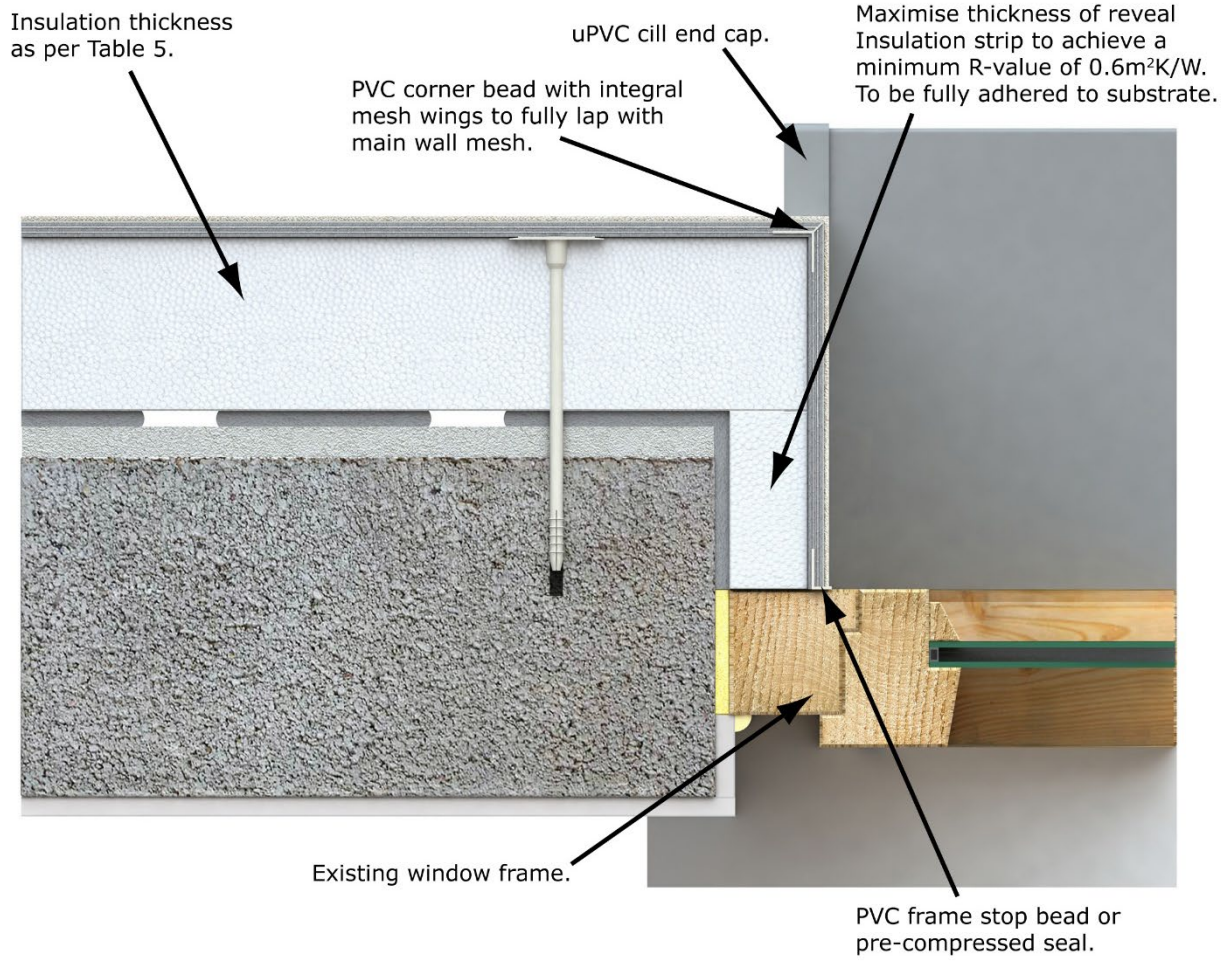

Figure 3: Sill and Reveal Detail

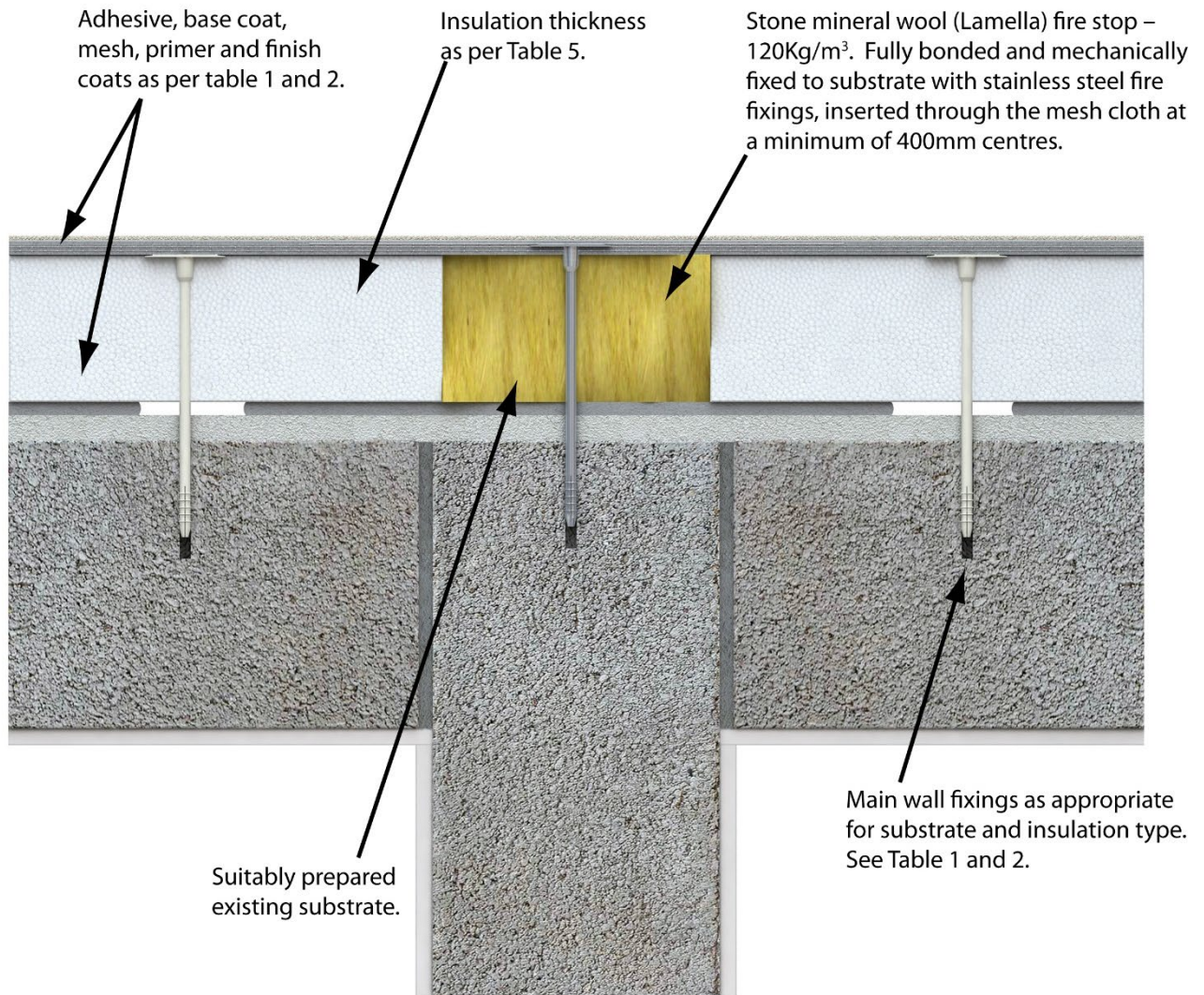

Figure 4: Vertical Fire-Stop Detail

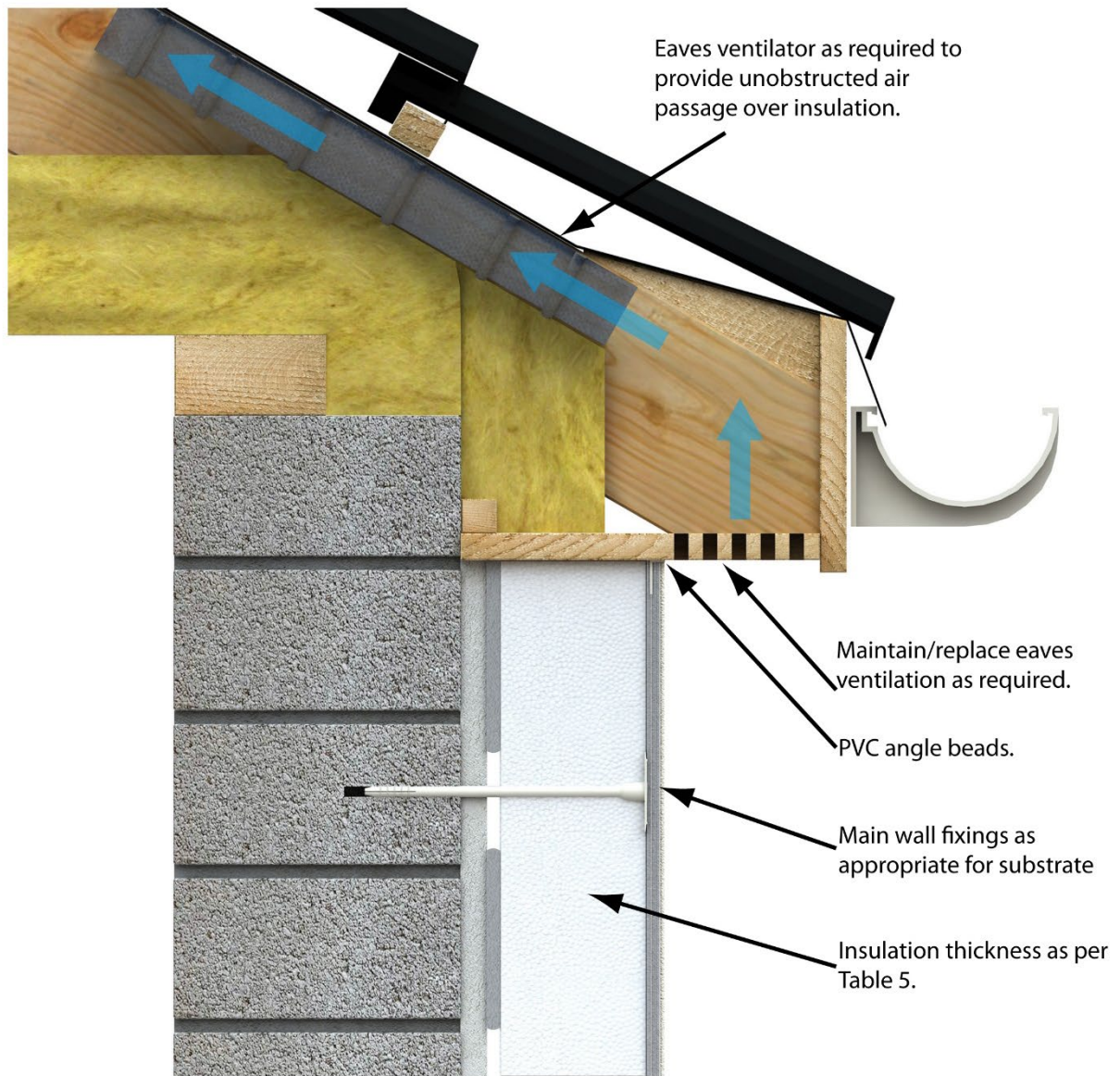
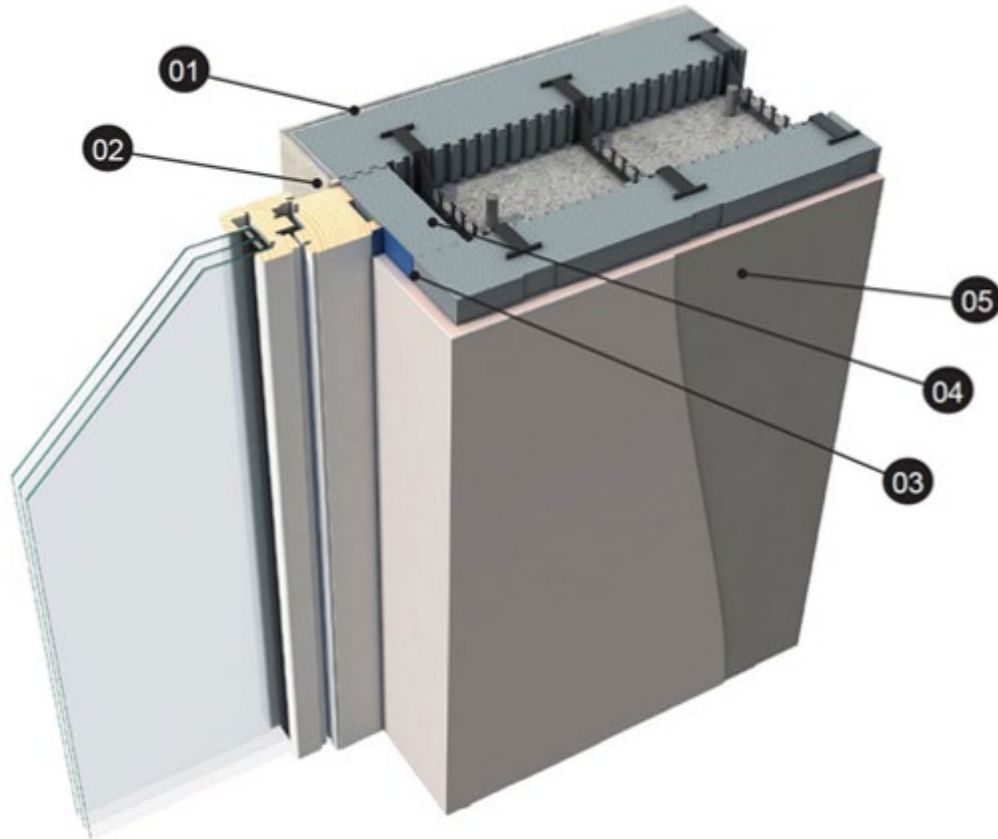

Figure 5: Eaves Detail



- 01. Soltherm P, ICF render only system.
- 02. Window frame sealed using the Soltherm reveal bead with gasket seal or similar, and silicone seal.
- 03. ICF system approved airtightness tape.
- 04. ICF System EPS Closure.
- 05. ICF system approved plasterboard.

Figure 6: Soltherm P, ICF render only system

3.1 GENERAL

The system is designed by BOLIX SA/Soltherm External Insulations Ltd or their Irish Agent/Distributor on a project specific basis. Where the external insulation system is being applied to improve the thermal performance of an existing building, Soltherm approved installer will assess the building and advise on how to maximise the benefits of the external insulation system for that building. The design will include for:

- a) The completion and recording of a site survey. For existing buildings, U-value calculations, pull-out resistance etc. should be based on the existing structure.
- b) Evaluation and preparation of substrate.
- c) Minimising risk of condensation in accordance with the recommendations of BS 5250^[2]. This includes the use of approved detailing as shown in Figures 1 to 8 incorporating the requirements of SR 54^[3] and, where possible, the Acceptable Construction Details published by DHPLG.
- d) Thermal insulation provision to Part L of the Building Regulations.
- e) Resistance to impact and abrasion.
- f) Resistance to thermal stresses.
- g) Resistance to wind loading.
- h) Design of fixings to withstand design wind loadings, using a safety factor of 3 (three) for mechanical fixings and a safety factor of 9 (nine) for adhesive. In addition, fixings around window and door openings shall be at a maximum of 300mm centres in each board or section of board so as to provide positive and robust restraint over the life of the system.
- i) The design for wind loading on buildings greater than 2 stories should be checked by a chartered engineer in accordance with Eurocode 1 I.S. EN 1991-1-4^[4].
- j) Design for fire resistance, fire spread and fire stopping, as defined in Section 4.2 and 4.3 of this Certificate.
- k) Design of a water management system to prevent ingress of water at movement joints, windows, doors, openings for services etc. Particular attention is required to ensure that window and sill design are coordinated to achieve a fully integrated design.
- l) Movement joints.
- m) A site specific maintenance programme for inclusion in the homeowner's documentation.
- n) Durability requirements.

Detailing and construction must be to a high standard to prevent the ingress of water and to achieve the design thermal performance. Window details should be designed such that, where possible, they can be removed and replaced from within the building. Consideration should be given to maximising improvement of thermal insulation at window reveals door openings etc. Adequate provision should be made at design and installation stage for the release of trapped moisture e.g. above window heads.

When designed and installed in accordance with this Certificate, the system will satisfy the requirements of Part L of the Building Regulations. The design shall include for the elimination/minimising of cold bridging at window and door reveals, eaves and at ground floor level in compliance with Acceptable Construction Details published by DHPLG.

The system is intended to improve the weather resistance of the external walls. Seals to windows and doors shall be provided in accordance with the project specific site plan. Care should be taken to ensure that any ventilation or drainage openings are not obstructed.

In areas where electric cables can come into contact with EPS, in accordance with good practice all PVC sheathed cables should be run through ducting or be re-routed. This is to prevent possible overheating of electrical cables and plasticiser leeching. Domestic gas installations must not be adversely affected by the fitting of external insulation. If the external insulation has an impact on the gas service line/meter location, then Bord Gáis Networks must be contacted so that a suitable solution can be achieved. If altering a gas installation, a Registered Gas Installer (RGI) must be employed.

The durability of the render systems is influenced by the colour of the render used. Further information is available by contacting the Certificate holder.

3.2 MAJOR RENOVATION

As external insulation over 25% of the building envelope is classified as Major Renovation in TGD to Part L of the Building Regulations, attention should be paid to Section 2.3 of TGD to Part L 2019 where external insulation is undertaken as part of a deep retrofit installation.

3.3 STRENGTH AND STABILITY

3.3.1 Wind Loading

The Soltherm P and MW Systems can be designed to withstand wind pressures (including suction) and thermal stresses in accordance with the Building Regulations. The design for wind loading on buildings greater than two stories should be checked by a chartered engineer in accordance with Eurocode 1 I.S. EN 1991-1-4^[4]. A general factor of safety of 1.5 is applied to design wind loads.

3.3.2 Impact Resistance

a) The Soltherm P and MW Systems have been classified as defined in Tables 4 and 5 to be suitable for use as defined in European Technical Assessment Guideline ETAG 004 / EAD 040083-00-0404 as follows:

Category I: A zone readily accessible at ground level to the public and vulnerable to hard impacts but not subject to abnormally rough use.

Category II: A zone liable to impacts from thrown or kicked objects, but in public locations where the height of the system will limit the size of the impact; or at lower levels where access to the building is primarily to those with some incentive to exercise care.

Category III: A zone not likely to be damaged by normal impacts caused by people or by thrown or kicked objects. Class III is taken to exclude the use on any wall at ground level.

Note: The above classifications do not include acts of vandalism.

In an Irish context, Category II excludes any wall at ground level adjacent to a public footpath but includes one with its own private, walled-in garden. Category III excludes all walls at ground level.

b) The design should include for preventing damage from impact by motor vehicles or other machinery. Preventive measures such as provision of protective barriers or kerbs should be considered.

To achieve category I impact resistance, renders must demonstrate no visible signs of damage when subjected to an impact of 10 Joules (J). Table 4 and 5 lists a range of Soltherm P and MW build-ups for a range of impact categories. In addition Table 4 (Category 1 build-up identified with an astrix *) lists the Soltherm premium product range, with double mesh layers, which while achieving category I, can also sustain impacts in excess of 40J.

When the Soltherm P render only system is being used as the external render system for a suitable ICF wall, reference shall be made to Section 2 and Table 4 of this certificate to ensure the approved build-ups achieve a minimum Category 1 impact resistance.

3.4 BEHAVIOUR IN RELATION TO FIRE

Systems that achieve at least a Class B Reaction to Fire Classification are suitable for use up to a maximum of six storeys (18 metres) in height on purpose groups 1(a), 1(b), 1(c), 2(a), 2(b), 3, 4(a) and 4(b), and for use up to a maximum of five storeys (15 metres) in height on purpose group 1(b), as defined in TGD to Part B of the Building Regulations.

Systems that achieve a Class A1 or Class A2-s1, d0 Reaction to Fire Classification have no restriction in height per TGD to Part B of the Building Regulations.

With regard to fire stopping and limitations on use of combustible materials, walls must comply with Sections 3.2, 3.3, 3.4 and 4 of TGD to Part B of the Building Regulations, and Sections 3.5, 3.6, 3.7 and 4 of TGD to Part B Volume 2 of the Building Regulations. Stainless steel fire fixings are to be provided at the rate of one per square metre when specified. The fixing design should take account of the extra duty required under fire conditions.

Vertical and horizontal lamella or stone mineral wool fire barriers shall be provided at each compartment floor and wall, with fixings provided at 400mm vertical centres and 400mm horizontal centres respectively, including the second floor level of a three-storey single occupancy house (see Diagram 12 of TGD to Part B Volume 2 of the Building Regulations. Firebreaks should be fully adhesively bonded to the substrate (i.e. ribbons or dabs of adhesive is not acceptable) and mechanically fixed with stainless steel fire fixings at 400mm centres. The fire barrier shall be of non-combustible material (i.e. stone mineral wool slab of minimum density 120kg/m³), be at least 200mm high, continuous and unbroken for the full perimeter of the building and for the full thickness of the insulation. Glass wool is not suitable for use as a firestop (see Clause 3.6.3 of TGD to Part B Volume 2 of the Building Regulations for types of suitable firestop).

3.5 PROXIMITY OF HEAT PRODUCING APPLIANCES

Combustible material must be separated from a brick or blockwork chimney by at least 200mm from a flue and 40mm from the outer surface of the brick or blockwork chimney, in accordance with Clause 2.5.6 of TGD to Part J of the Building Regulations. Metal fixings in contact with combustible materials should be at least 50mm from a flue.

3.6 VENTILATED CAVITIES

When the system is to be applied to a masonry cavity wall construction, consideration should be given to the treatment of the ventilated cavity. In order to maximise the thermal effectiveness of the improved U-value created by the external insulation system in a cavity wall/block of an external wall of a building, it is critical to significantly reduce or eliminate airflow within the cavity void. It is essential to seal the cavity to achieve an unventilated air layer. This eliminates heat losses due to airflow within the cavity circumventing the ETIC system. Best practice is to fill the cavity void with an NSAI Agrément approved Cavity Wall Insulation (CWI) system. Ventilation to the building must be maintained in accordance with the requirements of TGD to Part F of the Building Regulations.

3.7 CONDENSATION RISK

Areas where there is a significant risk of condensation due to high levels of humidity should be identified during the initial site survey.

3.7.1 Internal Surface Condensation

When improving the thermal performance of the external envelope of a building through external wall insulation, designers need to consider the impact of these improvements on other untouched elements of the building. As discussed in Section 4.5 of this Certificate, thermally bridged sections of the envelope such as window jambs, sills and eaves will experience a lower level of increased thermal performance. The degree of improvement to these junctions can be limited due to physical restrictions on site i.e. footpaths, soffit boards or hinges for windows.

When bridged junctions meet the requirements of Appendix D Table D2 of TGD to Part L of the Building Regulations, the coldest internal surface temperature will satisfy the requirements of Section D2, namely that the temperature factor shall be equal to or greater than 0.75. As a result, best practice will have to be adopted in order to limit the risk of internal surface condensation which can result in dampness and mould growth.

When site limiting factors give rise to substandard levels of insulation at bridged junctions, guidance should be sought from the Certificate holder as to acceptable minimum requirements.

3.7.2 Interstitial Condensation

Where an interstitial condensation risk is identified, an interstitial condensation risk analysis will be carried out by the certificate holder in accordance with BS 5250^[2] and the design modified as appropriate to reduce the risk of interstitial condensation to acceptable levels. Table 9 lists the s_d values for a range of build-ups.

3.7.3 Ventilation

When installing the external insulation system, the works to be undertaken must not compromise the existing ventilation provisions in the home, including the ventilation of suspended timber floors, where existing vents must be sleeved across the rising wall and sealed.

When these existing ventilation provisions do not meet the requirements of Part F of the Building Regulations, the homeowner should be informed, and remedial action should be taken before the external insulation system is installed.

3.8 MAINTENANCE

Adequate provision should be made in the initial design phase for access and maintenance over the life of the system.

The system shall be inspected and maintained in accordance with the Certificate holder's instructions, as detailed in the Repair and Maintenance Method Statement, which is incorporated into the Building Owner's Manual.

Necessary repairs should be carried out immediately and must be in accordance with the Certificate holder's instructions. Repairs to plumbing etc. should also be carried out as required to prevent deterioration or damage, and to protect the integrity of the system.

Synthetic finishes may be subject to aesthetic deterioration due to exposure to UV light. They should be re-painted every 18 to 20 years to maintain appearance. Care should be taken to ensure that the synthetic finish used is compatible with the original system and that the water vapour transmission or fire characteristics are not adversely affected.

Sealants shall be subject to regular inspection (at least annually). They should be replaced as required and fully replaced every 18 to 20 years to maintain performance according to the manufacturer's instructions.

3.9 WEATHERTIGHTNESS

When designed and detailed in accordance with this Certificate, the system will prevent moisture from the ground coming in contact with the insulation. The external render has adequate resistance to water penetration when applied in accordance with the Certificate holder's instructions.

Joint designs, sealant specifications and recommendations for detailing at windows and doors were assessed and are considered adequate to ensure that water penetration will not occur, assuming that regular maintenance is carried out in accordance with the Certificate holder's instructions.

3.10 AESTHETIC PERFORMANCE

As with traditional renders, the aesthetic performance of the systems, e.g. due to discolouration, soiling, staining, algal growth or lime bloom, is depended on a range of factors such as:

- Type, colour and texture of surface finish;
- Water retaining properties of the finish;
- Architectural form and detailing;
- Building orientation/elevation;
- Local climate/atmospheric pollution.
- Proximity to vegetation.

Where cleaning of walls is required, for example in the case of algal growth, the procedure in the Soltherm maintenance document must be followed which contains detailed information on the removal of algae. It is the homeowner's responsibility to inspect the walls every year and clean when required; however the homeowner may contract the approved installer to provide this service.

Adequate consideration should be given at the design stage to all of the above to ensure that the level of maintenance necessary to preserve the aesthetics of the building is acceptable.

4.1 IMPACT RESISTANCE

Tables 4 and 5 list the impact resistance classifications for various build-ups of the Soltherm P and MW systems.

4.2 REACTION TO FIRE

Tables 7 and 8 list the reaction to fire classification according to IS EN 13501-1^[5] for various build-ups of the Soltherm P and MW systems.

Table 7 of this certificate shows that the relevant Soltherm P render only system, when used with an approved ICF system, achieves a B-s1, d0 rating (per I.S. EN 13501-1) as is required in that ICF building system certificate.

4.3 THERMAL PERFORMANCE

Assessments were carried out to verify that the requirements of Part L of the Building Regulations can be achieved using Soltherm P and MW Systems. The manufacturer's declared thermal conductivity values ($\lambda_{90/90}$) taken from their CE Marking Declarations of Performance are 0.038W/mK for the standard white EPS board, 0.032W/mK and 0.031W/mK for the graphite enhanced EPS board, and 0.036W/mK for the mineral wool board (density 100-150kg/m³). These have not been assessed by NSAI Agrément.

Table 6 shows typical insulation thicknesses to achieve minimum U-values of 0.27W/m²K (retrofit only) and 0.21W/m²K for different construction types. The thermal resistance value for the render (R_{render}) can be taken as 0.02m²K/W.

Calculation of U-values will be required on individual projects to confirm a U-value of 0.27W/m²K has been achieved, based on the wall construction and the insulation used. The thermal conductivity (λ) value of the insulation to be used in all U-value calculations must be the $\lambda_{90/90}$ value.

4.4 LIMITING THERMAL BRIDGING

The linear thermal transmittance ' ψ ' (Psi) describes the heat loss associated with junctions and around openings. Window and door reveal design used on the Soltherm P and MW Systems have been assessed and when detailed in accordance with this Certificate can meet the requirements of Table D2 of TGD to Part L of the Building Regulations.

When **all** bridged junctions within a building comply with the requirements of Table D2 of TGD to Part L, the improved ' γ ' factor of 0.08 can be entered into the DEAP building energy rating (BER) calculation.

If **all** junctions can be shown to be equivalent or better than Acceptable Construction Details published by the DHPLG, then the values published in Table D2 apply.

Where either of the above options are shown to be valid, or when the required values cannot be achieved, all relevant details should be recorded on the 'Certificate of Compliance' for that project for use in future BER calculations.

' Ψ ' values for other junctions outside the scope of this Certificate should be assessed by an NSAI approved thermal modeller.

As per Acceptable Construction Details, a minimum thermal resistance of 0.6m²K/W should be provided at window reveals, heads and sills.

4.5 DESIGN LIFE

An assessment of the life of the system was carried out. This included an assessment of:

- Design and installation controls;
- Proposed building heights;
- Render thickness and specification;
- Material specifications, including insulant, mesh, beading and fixing specifications;
- Joint design;
- Construction details;
- Maintenance requirements.

The Soltherm P and MW systems can last in excess of 30 years subject to normal use, regular inspection and maintenance. It is important to note that the durability of the render system is entirely dependent on the correct installation of the product in accordance with this Certificate, the manufacturer's instructions, IS EN 13914-1^[1] and ongoing care and maintenance as described in Section 4.7 of this Certificate. Critical details include rendering at window sills, raised features, junctions with eaves and verges, and the use of suitably designed overhangs and flashings. Reference should be made to IS EN 13914-1^[1] for general advice on design, in particular on the use of angle, stop and movement beads.

4.6 PRACTICABILITY

The practicability of construction and the adequacy of site supervision arrangements were assessed and considered adequate. The project specific designs and method statements for application, inspection and repair were reviewed and found to be satisfactory.

4.7 TESTS AND ASSESSMENTS WERE CARRIED OUT TO DETERMINE THE FOLLOWING

- Structural strength and stability
- Behaviour in fire
- Impact resistance
- Pull-out resistance of fixings
- Thermal resistance
- Hygrothermal behaviour
- Condensation risk
- Site erection controls
- Durability of components
- Dimensional stability of insulants

4.8 OTHER INVESTIGATIONS

- (i) Existing data on product properties in relation to fire, toxicity, environmental impact and the effect on mechanical strength/stability and durability were assessed.
- (ii) The manufacturing process was examined including the methods adopted for quality control, and details were obtained of the quality and composition of the materials used.
- (iii) Special building details (e.g. ground level, window and door openings, window sill and movement joints) were assessed and approved for use in conjunctions with this Certificate.
- (iv) Site visits were conducted to assess the practicability of installation and the history of performance in use of the product.

Table 4: Impact Resistance - Soltherm P System

Base Coat	Finishing Coat	Reinforcement	Single Mesh		Double Mesh	
			Render Thickness < 6mm	Render Thickness ≥ 6mm	Render Thickness ≤ 9mm (Full range) Basecoat 4-6mm Render 1-3mm	Render Thickness ≥ 8mm
Soltherm UB	Acrylic Plaster (Soltherm AFC)	Soltherm 145/S, Soltherm 158/S, Soltherm 160/S or Soltherm 174/S	I		I	
Soltherm WB			III			
Soltherm BC-P			III	I		I
Soltherm UB Special			III			
Soltherm UB	Silicone Plaster (Soltherm SFC-P)		I		I	
Soltherm WB			III			
Soltherm BC-P			III	I	I* (40J)	I
Soltherm BC-P Quick			II			
Soltherm UB Special			I			
Soltherm UB	Silicate Plaster (Soltherm STF)		II		I	
Soltherm WB			II			
Soltherm BC-P			II			
Soltherm UB Special			II			
Soltherm UB	Mineral Plaster (Soltherm MTC)		II		I	
Soltherm WB			III			
Soltherm BC-P			III			
Soltherm UB Special			II			
Soltherm UB	Silicate-Silicone Plaster (Soltherm AF-P+)		I		I	
Soltherm WB			III			
Soltherm BC-P			III	I		
Soltherm BC-P Quick		II				
Soltherm UB Special		II				
Soltherm UB	Mosaic Plaster (Soltherm AMC)	II		I	I	
Soltherm UB Special		II				
Soltherm BC-P Quick	Silicate-Silicone Plaster (Soltherm AF-P+) + Soltherm 4 Seasons	II		II		
	Silicone Plaster (Soltherm SFC-P) + Soltherm 4 Seasons	II		II		
Soltherm UB / Soltherm UB Special / Soltherm BC-P Quick	Soltherm Dash Receiver (Soltherm SDR)	II				

Table 5: Impact Resistance SOLTHERM MW				
Base Coat	Finishing Coat	Reinforcement	Single Mesh	Double Mesh
MW panels + Soltherm MB	Soltherm MTC	Soltherm 145/S, Soltherm 158/S or Soltherm 160/S	II	I
	Soltherm STF		II	I
	Soltherm SFC-P /Soltherm SFC-P eco-shield		II	I
	Soltherm SFC-P+		I	I
	Soltherm AF-P+		I	I
MW lamella + Soltherm MB	Soltherm MTC		III	III
	Soltherm STF		II	II
	Soltherm SFC-P /Soltherm SFC-P eco-shield		II	II
	Soltherm SFC-P+		I	I
	Soltherm AF-P+		I	I
MW panels + Soltherm MB	Soltherm MTC	Soltherm HD 174/S	III	III
	Soltherm STF		I	I
	Soltherm SFC-P /Soltherm SFC-P eco-shield		II	II
MW lamella + Soltherm MB	Soltherm MTC		III	III
	Soltherm STF		II	II
	Soltherm SFC-P /Soltherm SFC-P eco-shield		II	II
MW panels + Soltherm MB or Soltherm UB Special	Soltherm Dash Receiver (Soltherm SDR)	Soltherm 145/S, Soltherm 158/S, Soltherm 160/S or Soltherm 174/S	II	I
MW panels + Soltherm UB Special	Soltherm MTC	Soltherm 145/S, Soltherm 158/S or Soltherm 160/S	II	II
	Soltherm STF		I	I
	Soltherm SFC-P /Soltherm SFC-P eco-shield		I	I
	Soltherm SFC-P+		I	I
	Soltherm AF-P+ /Soltherm AF-P+ eco-shield		I	I
MW lamella + Soltherm UB Special	Soltherm MTC		II	II
	Soltherm STF		II	II
	Soltherm SFC-P /Soltherm SFC-P eco-shield		II	II
	Soltherm AF-P+ /Soltherm AF-P+ eco-shield		I	I

Table 5: Impact Resistance - Soltherm MW System

Existing Wall Structure	Insulation Material	Thermal Conductivity ($\lambda_{90/90}$) of Insulation (W/mK)	U-Value (thickness of insulation) W/m ² K					
			0.27	0.25	0.21	0.17	0.15	0.11
215mm Block on Flat (No insulation)	EPS 70 White	0.038	130mm	140mm	170mm	210mm	240mm	330mm
	EPS 70 SILVER	0.031	110mm	120mm	140mm	170mm	200mm	270mm
	Mineral Wool	0.036	120mm	130mm	160mm	200mm	230mm	320mm
215mm Hollow Block (No insulation)	EPS 70 White	0.038	130mm	140mm	170mm	210mm	240mm	330mm
	EPS 70 SILVER	0.031	100mm	110mm	140mm	170mm	200mm	270mm
	Mineral Wool	0.036	120mm	130mm	160mm	200mm	230mm	310mm
Concrete Block Cavity Wall (No insulation)	EPS 70 White	0.038	120mm	130mm	160mm	210mm	240mm	330mm
	EPS 70 SILVER	0.031	100mm	110mm	130mm	170mm	190mm	270mm
	Mineral Wool	0.036	120mm	130mm	160mm	200mm	220mm	320mm
Concrete Block Cavity Wall 100/100/100 (50mm Cavity insulation $\lambda = 0.039$ W/mK)	EPS 70 White	0.038	70mm	90mm	110mm	160mm	190mm	280mm
	EPS 70 SILVER	0.031	60mm	70mm	90mm	130mm	150mm	230mm
	Mineral Wool	0.036	70mm	80mm	110mm	150mm	180mm	260mm
Concrete Block Cavity Wall 100/100/100 (50mm Cavity insulation $\lambda = 0.033$ W/mK)	EPS 70 White	0.038	70mm	80mm	110mm	150mm	180mm	270mm
	EPS 70 SILVER	0.031	50mm	60mm	90mm	120mm	150mm	220mm
	Mineral Wool	0.036	60mm	70mm	100mm	140mm	170mm	260mm
Concrete Block Cavity Wall 100/100/100 (100mm Cavity insulation $\lambda = 0.039$ W/mK)	EPS 70 White	0.038	30mm	40mm	70mm	120mm	150mm	240mm
	EPS 70 SILVER	0.031	30mm	40mm	60mm	90mm	120mm	190mm
	Mineral Wool	0.036	30mm	40mm	70mm	110mm	140mm	230mm
Concrete Block Cavity Wall 100/100/100 (100mm Cavity insulation $\lambda = 0.035$ W/mK)	EPS 70 White	0.038	20mm	30mm	60mm	100mm	130mm	230mm
	EPS 70 SILVER	0.031	20mm	30mm	50mm	90mm	110mm	190mm
	Mineral Wool	0.036	20mm	30mm	60mm	100mm	130mm	210mm

All calculation assume horizontal heat flow, unventilated cavities <25mm with a thermal resistance of 0.18m²K/W, 18mm of existing external render $\lambda = 1.0$ W/mK, Concrete blocks (thickness as specified) $\lambda = 1.35$ W/mK, 16mm internal plaster $\lambda = 0.3$ W/mK or 12.5mm plaster board $\lambda = 0.25$ W/mK

Table 6: Soltherm P and MW Systems Typical U-values (W/m²K)

SOLTHERM P – Reaction to Fire			
ETICS system description	Maximum declared organic content	Thickness	Class according to EN 13501-1
ETICS Soltherm P with rendering system: <ul style="list-style-type: none"> • Adhesives: SOLTHERM UB, SOLTHERM UB Special, SOLTHERM SA, SOLTHERM WB/ SOLTHERM BC-P • EPS of thickness up to and including 250 mm • Glass fibre meshes according to Table 1 • Base coats: SOLTHERM UB, SOLTHERM UB Special, SOLTHERM WB/ SOLTHERM BC-P • Finishing coats SOLTHERM (with relevant key coats according to table 1): AFC 20, AFC 10, AFC 15, AFC i, AFC 25wt, AFC 15wt, RMG, AMG, AFC 20 eco-shield, AFC 15 eco-shield, AFC 10 eco-shield, AFC 25wt eco-shield, AFC 15wt eco-shield, AFC i eco-shield, AFC s eco-shield. SFC-P 20, SFC-P 15, SFC-P25 wt, AF-P+ 20, AF-P+ 15. • Decorative finishes Soltherm (with relevant primers according to table 1): ACP, STC-P, STPT. 	adhesives/base coats $\leq 4.3\%$ finishing coats $\leq 11.7\%$ decorative finishes $\leq 17.0\%$	50 - 250	B-s1, d0
ETICS Soltherm P with rendering system: <ul style="list-style-type: none"> • EPS of thickness up to and including 250 mm • Adhesives: Soltherm UB, Soltherm UB Special, Soltherm SA, Soltherm WB / Soltherm BC-P • Glass fibre meshes according to Table 1 • Base coats: Soltherm UB, Soltherm UB Special, Soltherm WB / Soltherm BC-P • Finishing coats Soltherm (with relevant key coats according to table 1): MTC 15, MTC 20, MTC 30, MTC 25wt, MTC 15g, MTC 15wtg, STF 10, STF 15, STF 20, STF 25wt, SDR • Decorative finishes Soltherm (with relevant primers according to table 1): ACP, STC-P, STPT 	adhesives/base coats $\leq 4.3\%$ finishing coats $\leq 3.5\%$ decorative finishes $\leq 17,0\%$	50 - 250	B-s1, d0
ETICS Soltherm P with rendering system: <ul style="list-style-type: none"> • EPS of thickness up to and including 250 mm • Adhesives: Soltherm SA, Soltherm AL, Soltherm UB, Soltherm WB • Base coats: Soltherm BC-P Quick • Glass fibre meshes according to Table 1 • Finishing coats: Soltherm AF-P+, Soltherm SFC-P • Finishing coat + setting accelerator (Soltherm 4 Seasons) 	adhesives/base coats $\leq 4.6\%$ finishing coats $\leq 8.0\%$	50 – 250	B-s2, d0

Table 7: Soltherm P System – Reaction to Fire

SOLTHERM MW – Reaction to Fire			
Configuration	Max heat of combustion (MJ/kg)	Flame retardant content	Euroclass according to EN 13501-1
Adhesive	0.34	No flame retardant	A1
MW boards (organic content in quantity ensuring Euroclass A1 according to EN 13501-1), density $\leq 130\text{kg/m}^3$	-		
Base coat	0.34		
Glass fibre mesh	8.61		
Key coat: Soltherm AP Colour Soltherm AP	6.65		
Finishing coat: Soltherm MTC	0.0		
Key coat: Soltherm SNP	3.98		
Decorative coat: Soltherm STC-P / Soltherm STC-P eco-shield	1.99		
Adhesive	0.34	No flame retardant	A2-s1, d0*
MW boards (organic content in quantity ensuring Euroclass A1 according to EN 13501-1), density $\leq 130\text{kg/m}^3$	-		
Base coat	0.34		
Glass fibre mesh	8.61		
Key coat	5.68		
Finishing coat	2.65		
Key coat	7.33		
Decorative coat	4.60		
Adhesive	0.29	No flame retardant	A1
MW boards (organic content in quantity ensuring Euroclass A1 according to EN 13501-1), density $\leq 130\text{kg/m}^3$	-		
Base coat	0.29		
Glass fibre mesh	8.61		
Finishing coat: Soltherm SDR	-0.02		

* For configurations of Soltherm MW not covered by Euroclass A1

Table 8: Soltherm MW System – Reaction to Fire

Soltherm P		
Base Coat	Finishing Coat	Equivalent Air Layer Thickness s_d
All base coats	All finish coats	$\leq 2.0\text{m}$
Soltherm MW		
Base Coat	Finishing Coat	Equivalent Air Layer Thickness s_d
All base coats	All finish coats	$\leq 1.0\text{m}$

Table 9: Water Vapour Permeability

5.1 National Standards Authority of Ireland ("NSAI") following consultation with NSAI Agrément has assessed the performance and method of installation of the product/process and the quality of the materials used in its manufacture and certifies the product/process to be fit for the use for which it is certified provided that it is manufactured, installed, used and maintained in accordance with the descriptions and specifications set out in this Certificate and in accordance with the manufacturer's instructions and usual trade practice. This Certificate shall remain valid for five years from date of latest revision so long as:

- (a) the specification of the product is unchanged.
- (b) the Building Regulations and any other regulation or standard applicable to the product/process, its use or installation remains unchanged.
- (c) the product continues to be assessed for the quality of its manufacture and marking by NSAI.
- (d) no new information becomes available which in the opinion of the NSAI, would preclude the granting of the Certificate.
- (e) the product or process continues to be manufactured, installed, used and maintained in accordance with the description, specifications and safety recommendations set out in this certificate.
- (f) the registration and/or surveillance fees due to NSAI are paid.

5.2 The NSAI Agrément mark and certification number may only be used on or in relation to product/processes in respect of which a valid Certificate exists. If the Certificate becomes invalid the Certificate holder must not use the NSAI Agrément mark and certification number and must remove them from the products already marked.

5.3 In granting Certification, the NSAI makes no representation as to;

- (a) the absence or presence of patent rights subsisting in the product/process; or
- (b) the legal right of the Certificate holder to market, install or maintain the product/process; or
- (c) whether individual products have been manufactured or installed by the Certificate holder in accordance with the descriptions and specifications set out in this Certificate.

5.4 This Certificate does not comprise installation instructions and does not replace the manufacturer's directions or any professional or trade advice relating to use and installation which may be appropriate.

5.5 Any recommendations contained in this Certificate relating to the safe use of the certified product/process are preconditions to the validity of the Certificate. However the NSAI does not certify that the manufacture or installation of the certified product or process in accordance with the descriptions and specifications set out in this Certificate will satisfy the requirements of the Safety, Health and Welfare at Work Act, or of any other current or future common law duty of care owed by the manufacturer or by the Certificate holder.

5.6 The NSAI is not responsible to any person or body for loss or damage including personal injury arising as a direct or indirect result of the use of this product or process.

5.7 Where reference is made in this Certificate to any Act of the Oireachtas, Regulation made thereunder, Statutory Instrument, Code of Practice, National Standards, manufacturer's instructions, or similar publication, it shall be construed as reference to such publication in the form in which it is in force at the date of this Certification.

NSAI Agrément

This Certificate No. **12/0371** is accordingly granted by the NSAI to **BOLIX SA** on behalf of NSAI Agrément.

Date of Issue: **June 2012**

Signed



Seán Balfé
Director of NSAI Agrément

Readers may check that the status of this Certificate has not changed by contacting NSAI Agrément, NSAI, 1 Swift Square, Northwood, Santry, Dublin 9, Ireland. Telephone: (01) 807 3800. Fax: (01) 807 3842. www.nsaie.com

Revision:

- **November 2015:** System name change and system component names amended to new marketing names.
- **September 2018:** References to Building Regulations and standards updated.
- **21st February 2023:** Addition of new base coat, finish coats, dash and Soltherm P render only system on to ICF.

Bibliography

- [1] I.S. EN 13914-1:2016 *Design, preparation and application of external rendering and internal plastering – External rendering.*
- [2] BS 5250:2016 *Code of practice for control of condensation in buildings.*
- [3] SR 54:2014 & A2 2022: *Code of practice for the energy efficient retrofit of dwellings.*
- [4] I.S. EN 1991-1-4:2005/A1 2010: *Actions on structures – General actions – Wind actions.*
- [5] I.S. EN 13501-1:2018 *Fire classification of construction products and building elements – Classification using data from reaction to fire tests.*
- [6] ETAG 004: *External Thermal Insulation Composite Systems (ETICS) with Rendering (Superseded by item 7)*
- [7] EAD 040083-00-0404 EAD: 2019: *External Thermal Insulation Composite Systems (ETICS) with Renderings*
- [8] I.S. EN 13164: *Thermal insulation products for buildings - Factory made extruded polystyrene foam (XPS) products – Specification: 2012+A1:2015*
- [9] EN13162: *Thermal insulation products for buildings - Factory made mineral wool (MW) products – Specification: 2012+A1:2015*
- [10] EN13163: *Thermal insulation products for buildings - Factory made expanded polystyrene (EPS) products – Specification: 2012+A2:2016*