



**IRISH AGRÉMENT BOARD
CERTIFICATE NO. 17/0391**

Vision Built Manufacturing Ltd,
Unit 1, Deerpark Industrial Estate,
Oranmore, Galway, H91 V6PF,
Ireland.

E: www.vision-built.com
T: (091) 795505

Vision Built Steel Frame Building System
Systemes pour constructions
Bausystem

NSAI Agrément (Irish Agrément Board) is designated by Government to carry out European Technical Assessments.

NSAI Agrément Certificates establish proof that the certified products are '**proper materials**' suitable for their intended use under Irish site conditions, and in accordance with the **Building Regulations 1997 and subsequent revisions**.



PRODUCT DESCRIPTION:

This Certificate relates to the Vision Built Steel Frame Building System, for the manufacture and erection of structural cold-formed Light Gauge Steel (LGS) Frame Buildings. The Vision Built Steel Frame Building System is certified to be used in the following purpose groups 1(a), 1(b), 1(c), 1(d), 2(a), 2(b), 3, 4(a) and 5 as defined in Technical Guidance Document B of the Irish Building Regulations. The system is used for structural walls and floors in the above purpose groups up to ten storeys in height or as part of a building not more than 30m in height, where the full structure is designed, manufactured, supplied and erected by Vision Built. The system can accommodate a wide range of custom designs.

The Vision Built System is also assessed for use in non-loadbearing infill panels. The infill panels are used within reinforced concrete, steel frames and traditional construction that possess their own independent lateral stability systems.

Site erection is carried out by approved installers employed by Vision Built or specialist sub-contractors under the supervision of Vision Built.

USE:

The system is certified for B6 the following applications:

1. To provide the structure of a building up to 10 storeys in height, which can accommodate either a composite concrete profile metal deck or a cold formed section floor.
2. The system can also be used as the top storeys (Penthouse) of a building more than 30m in height. The Vision Built Steel Frame element of the building must be constructed off a concrete floor or non-combustible podium/transfer slab.
3. Vision Built Structural Steel Frame (SFS) non-loadbearing infill panels can be used in building more than 30m in height. The infill panels can be incorporated in concrete or steel framed building systems which possess their own independent lateral stability systems.

Readers are advised to check that this Certificate has not been withdrawn or superseded by a later issue by contacting NSAI Agrément, NSAI, Santry, Dublin 9 or online at www.nsai.ie



DESIGN:

The Vision Built Steel Frame Building System is intended for use where architect's finalized construction and fire strategy drawings are available and satisfy the Irish Building Regulations 1997 and subsequent revisions. The architect and engineer design team of the developer (the client) is responsible for the architectural drawings and overall building design to comply with the Building Regulations.

The Vision Built Chartered Structural Engineer is responsible for the final design of the Vision Built Steel Frame Building System. The system is designed for use in permanent buildings with a brick/block external wall finish with a wide range of traditional roofing finishes.

The system may also be designed to incorporate NSAI Agrément approved or equivalent alternative roofing and external wall cladding systems. However, written approval must be sought from Vision Built Chartered Structural Engineer on the use of such claddings. The buildings are assembled using a panelised system, factory made and site assembled.

MARKETING, DESIGN AND MANUFACTURE:

The product is designed and manufactured by:

Vision Built Manufacturing Ltd,
Unit 1,
Deerpark Industrial Estate,
Oranmore,
Galway,
H91 V6PF,
Ireland.
www.vision-built.com
Tel (091) 795505

The product is marketed and erected by:

Vision Built Structures Ltd,
Unit 1,
Deerpark Industrial Estate,
Oranmore,
Galway,
H91 V6PF,
Ireland.
www.vision-built.com
Tel (091) 795505

1.1 ASSESSMENT

In the opinion of the NSAI (National Standards Authority of Ireland) Agrément Board, the Vision Built Steel Frame Building System if used in accordance with this Certificate can meet the requirements of the Irish Building Regulations 1997 and subsequent revisions, as indicated in Section 1.2 of this Agrément Certificate.

1.2 BUILDING REGULATIONS

REQUIREMENTS:

Part D – Materials and Workmanship

D3 – Proper Materials

The Vision Built Steel Frame Building System, as certified in this Certificate, is comprised of 'proper materials' fit for their intended use (see Part 4 of this Certificate).

D1 – Materials & Workmanship

The Vision Built Steel Frame Building System, as certified in this Certificate, can meet the requirements for workmanship.

Part A - Structure

A1 – Loading

The Vision Built Steel Frame Building System once appropriately detailed, designed and constructed has adequate strength and stability to meet the requirements of this Regulation (see Part 3 of this Certificate).

A2 – Ground Movement

An appropriately designed ground floor or podium slab can safely sustain the combined dead, imposed and wind loads of the system into the foundation structure without causing undue deflection to any part of the building.

Part B – Fire Safety

B1&B6 – Means of Escaped in Case of Fire

Windows in the ground or higher floors may be used as a means of escape in the case of fire.

B2&B7 – Internal Fire Spread (Linings)

The plasterboard side of walls and ceilings is designated Class 0. It may therefore be used on the internal surfaces of buildings of every purpose group without restriction.

B3&B8 – Internal Fire Spread (Structure)

The Vision Built Steel Frame Building System is designed and constructed so that its stability will be maintained for a reasonable period in the event of fire in compliance with Section B3 of TGD B to the Building Regulations.

B4&B9 – External Fire Spread

External masonry walls have a Class 0 surface spread of flame rating and when installed and used in the context of this Certificate will provide adequate resistance to the spread of flame over the external walls and roofs and can satisfy the relevant requirements of this Regulation as indicated in Section 4.1 of this Certificate.

Part C – Site Preparation and Resistance to Moisture

C3 – Dangerous Substances

Each dwelling ground floor must include a radon sump and provide the facility for radon extraction. Where it is shown that protection from dangerous substances e.g. radon, is required, an approved gas resistant membrane and gas handling system must be provided under the ground floor. Vision Built Steel Frame Building System permits the incorporation of the appropriate membrane, sump and gas handling system.

C4 – Resistance to Weather and Ground Moisture

Vision Built Steel Frame Building System has adequate damp-proof courses and membranes to resist the passage of moisture from the ground.

Roof and external walls above site Damp Proof Course (DPC) level will have adequate weather resistance in all exposures to prevent the passage of moisture from the external atmosphere into the building as specified in section 4.6 of this Certificate.

Part E – Sound

E1 – Airborne Sound (Walls)

Walls can be appropriately detailed and constructed to meet the airborne sound level performance outlined in Table 1 of TGD E of the Building Regulations, provided good workmanship is adhered to onsite. (See also Section 4.5, Figure 13 and Figure 14 of this Certificate).

E2 & E3 – Airborne and Impact Sound (Floors)

Separating floors can be constructed to meet the airborne and impact sound level performance outlined in Table 1 of TGD E, provided good workmanship is adhered to onsite (see Figure 15, Figure 17 and Figure 18).

Part F – Ventilation

F1 (a) – Means of Ventilation

Adequate ventilation openings are provided in internal and external walls and in roofs to meet this requirement. Walls and roofs used in the system can be designed and constructed to prevent any harmful effect from interstitial or inner surface condensation, to comply with the requirements of BS 5250:2011+A1:2016 *Code of practice for the control of condensation in buildings*.

F1 (b) – Limiting the concentration of harmful pollutants in the air within the building

The ventilation rate is required to be designed to meet the level of air pollutants present in the building. This will be based on the project specific design.

F2 – Condensation in Roofs

Adequate ventilation is provided in roofs to meet this requirement (see Section 4.4.2 of this Certificate).

Part J – Heat Producing Appliances

J1- Air Supply

The system can provide an adequate supply of permanent combustible air by means of air ducts, to obviate draughts, within the room in which the fireplace is located.

J3- Protection of Building

When used in accordance with Section 4.1.4 of this Certificate, wall lining insulation and separation distances meet the Building Regulation requirements.

Part L – Conservation of Fuel and Energy

- **Dwellings**
- **Buildings other than Dwellings**

L1 – Conservation of Fuel and Energy

All building elements of the Vision Built Steel Frame Building System can be readily designed to incorporate the required thickness of insulation to meet a wide range of required elemental U-values. The elemental U-values are calculated using the elemental heat loss method calculations for walls as per TGD to Part L of the Building Regulations (see Section 4.2 and Table 5).

The system can readily be detailed to accommodate a wide variety of plan forms and users of the system must ensure that Building Regulation requirements (avoidance of cold bridging) that are affected by plan form and internal sub-division of the building are complied with.

Thermally bridged junctions have been assessed for both their linear thermal transmittance (i.e. Psi-value (ψ -value) and their temperature factors (f_{Rsi}) in accordance with the procedures outlined in IP 1/06 "Assessing the effects of thermal bridging at junctions and around openings" and BRE report BR 479 "Conventions for calculating linear thermal transmittance and temperature factors" and IS EN ISO 10211:2007 *Thermal Bridges in Building Construction - Heat Flows and Surface Temperatures - Detailed Calculations*. As a result, best practice has been observed to limit heat loss due to thermal bridging and minimising the risk of mould growth due to surface condensation.

Part M – Access for People with Disabilities

M1 – Access and Use

Buildings can be designed to meet the access, circulation and facilities requirements of this Regulation (see Section 4.6 of this Certificate).

M2 – Sanitary Conveniences

Buildings can be designed to meet the installation requirements for sanitary conveniences for people with disabilities (see Section 4.6 of this Certificate).

2.1 PRODUCT DESCRIPTION

This Certificate relates to the Vision Built Steel Frame Building System for the design, manufacture and erection of cold-formed light gauge steel frame buildings. Buildings using this system are erected on site using a panelised system factory made and site assembled with all major custom components being manufactured at a Vision Built production facility.

Vision Built produces all cold-formed steel sections using (CNC) computer numerically controlled plant. Rigid insulation board is placed on the cavity side of the cold formed steel studs and the rigid insulation board serves to encase the cold formed steel sections thus creating a "warmframe" environment for the steel frame.

2.1.1 External Walls

The external walls can be load bearing or non-load bearing. Rigid Polyisocyanurate (PIR) or Phenolic insulation boards are fitted to the cavity side of the cold formed steel studs. A minimum of 4.2mm spray polyurethane (PUR) insulation is applied between the studs to the back of the rigid insulation board and the remainder of the wall panel is filled with stone mineral wool between the studs for additional acoustic and fire properties (Figure 1). The wall panels are then clad with the required thickness and grade of plasterboard as per Table 4 to achieve the appropriate fire performance rating required for the building. The plasterboards are screw fixed to the cold formed steel stud and track members.

The requirements for the provision of an Air and Vapour Control Layer (AVCL) on external walls are outlined in section 4.4 of this certificate.

2.1.2 External Cladding and Wall Ties

The external leaf of the Vision Built Steel Frame Building System is generally of traditional brick/block masonry to IS 325-1:1986 *Code of practice for use of masonry – Structural use of un-reinforced masonry* and IS EN 1996-1-1:2005 Eurocode 6 *Design of Masonry Structures - Part 1-1: General Rules for Reinforced and Unreinforced Masonry Structures (including Irish National Annex)* or other claddings approved by the NSAI Agrément. The masonry outer leaf is tied to the Vision Built Steel Frame Building System with a stainless-steel slot and channel cavity wall tie system in accordance with IS EN 845-1:2013 *Specification for ancillary components for masonry Part 1: Wall Ties, Tension Straps, Hangers and Brackets*. The tie is intended to be used in masonry to studded applications, with a design

cavity width of 50mm in accordance with IS 325-1:1986. The cavity width is defined as the distance between the outer surface of the rigid board insulation and the inner surface of the masonry leaf. The wall tie system comprises of two parts, the channel incorporates a slot and is factory fitted through the rigid board insulation with the required depth of tech screw directly into the flange of the cold formed studs. The tie channels are fitted at each cold-formed steel studs at a frequency that can accommodate the requirements for wall tie spacing as outlined in IS EN 1996-1-1:2005 *Eurocode 6*.

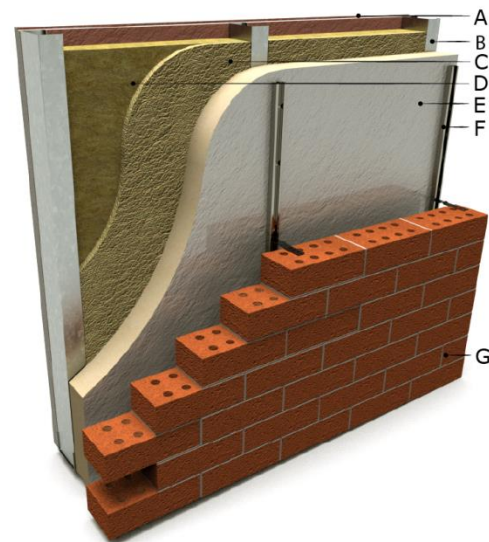

- | | |
|---------------------------------|---------------------------------------|
| A Plasterboard | E P.I.R./Phenolic Insulation |
| B Steel Stud | F Stainless Steel Wall Channel |
| C Closed Cell Insulation | G External Masonry Wall |
| D Rockwool | |

Figure 1: External wall detail illustrating how wall tie system and insulation is fixed to steel frame

Using this channel system allows for variations within block/brick courses. Around openings, channels are positioned within 150mm of the opening, and line up with the steel studs. The slot in the wall tie bracket enables a wall tie to be adjusted vertically for variations in mortar thickness during construction of the masonry outer leaf. Additional wall ties are provided at 225mm centres around all openings, corners and movement joints, such that there is a tie for each 225mm of perimeter of opening or either side of each movement joint/corner. Wall ties are available as standard flat ties.

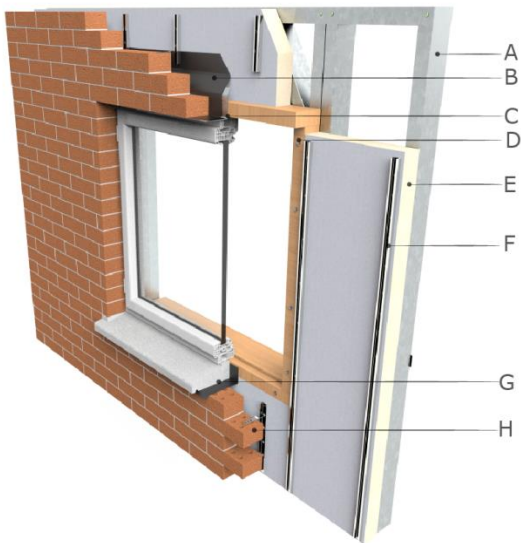

- | | |
|--------------------------|---------------------------------------|
| A Steel Stud | E P.I.R./Phenolic Insulation |
| B DPC | F Stainless Steel Wall Channel |
| C Steel Z-Section | G Window Cill |
| D Timber Batten | H External Masonry Wall |

Figure 2: Window Opening illustrating different construction elements

The wall ties have been assessed and meet the performance requirements given IS EN 845:2013 for a Type 6 wall tie and designed in accordance with IS EN 1996-1-1:2005+A1:2012. Where masonry cladding is being used over 4 storeys' (12m) in height, a Type 1 wall tie in accordance with IS EN 845:2013 must be used. The wall tie and channel are made from minimum Grade 304 austenitic stainless steel. Figure 1 and Figure 2 illustrates how the wall tie system is fixed to steel frame.

The cavity in the external wall must be maintained and kept clear of construction debris to 150 mm below DPC level. Masonry claddings must have adequate weep holes along their base and over openings to allow moisture exit the cavity.

2.1.3 Internal Walls

The internal load bearing and non-load bearing wall panels are made from cold-formed LGS. When internal wall panels provide racking resistance to external walls, diagonal wind bracing members can be incorporated into the panel to successfully transfer the horizontal loads safely through the building structure in accordance with structural design requirements. The bracing also serves to keep the frames square during erection.

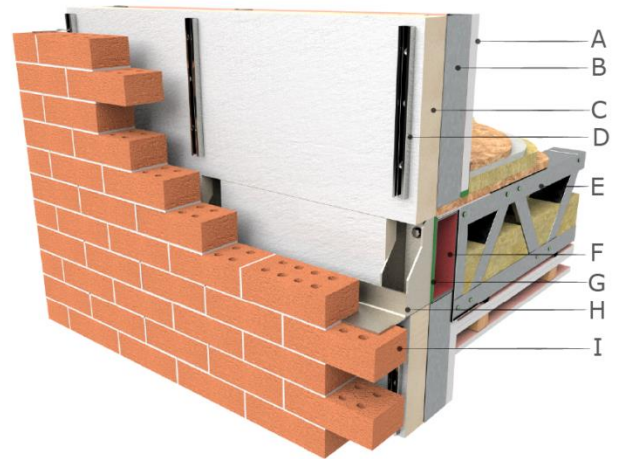

- | | |
|-------------------------------------|--------------------------------|
| A Plasterboards | F Hot Roll Steel |
| B Steel Stud | G Thermal Break |
| C P.I.R./Phenolic Insulation | H Masonry Support |
| D Stainless Steel Channel | I External Masonry Wall |
| E Steel Lattice Truss | |

Figure 3: Masonry Support Detail

All internal load bearing panels must be sufficiently supported directly under the panels with rising blockwork or equivalent. Plasterboard specifications on the steel panels should be in accordance with Table 4 of this certificate, which shows the plasterboard fire resistance requirements for wall, floor and ceiling elements. The plasterboard and AVCL linings are fixed to the walls and ceilings by means of self-drill/self-tap screws; all joints are then taped and filled. This method of fixing the plasterboard eliminates nail popping.

2.1.4 Compartment Floor

Compartment floors as described in Table 4 of this certificate will have a prescribed fire-resistant classification which can be used in the separation of one fire compartment from another.

Vertically distributed services, such as waist pipes, ventilation ducts and electrical cabling can be accommodated in compartment floors. Service penetrations through a compartment floor needs to be adequately protected by sealing or fire-stopping so that the fire resistance is not impaired in accordance with TGD B of the Building Regulations.

Horizontal distribution of services can be accommodated within a service cavity created external to the un-breached linings of the fire-resistant compartment floor on the underside of the ceiling below as illustrated in Figure 4.

For additional acoustic performance, resilient bars may be added where specified and are fixed to the underside of the floor joists to facilitate the fixing of plasterboard lining to the required specification.

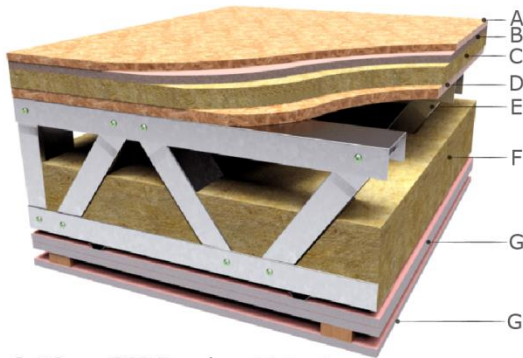

- | | |
|-----------------------------|-------------------------------------|
| A 18mm OSB Board | E Steel Lattice Truss |
| B 19mm Plasterboard | F 100mm Rockwool Insulation |
| C Rigid Mineral Wool | G 2x15mm Type 5 Plasterboard |
| D 18/22mm OSB Board | G 12.5mm Plasterboard |

Figure 4: Truss separating floor with services accommodated in service cavity to the underside of the fire resisting plasterboard.

2.1.5 Domestic Floor 30 minutes Fire Resistance

The floor consists of galvanised cold formed steel trusses at maximum 600mm centres fixed to a perimeter galvanised cold formed 'Z' or 'C' section, with a minimum covering of 22mm tongued and grooved (T&G) WBP plywood or OSB3. The floor trusses are project specifically designed, and are typically formed from the range of section sizes and thicknesses outlined in Table 2.

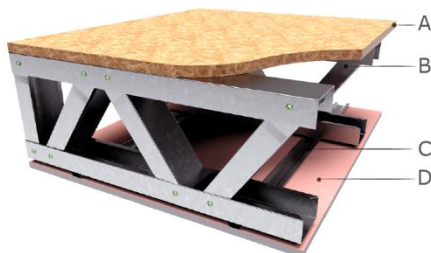

- | | |
|------------------------------|------------------------------|
| A 18mm OSB Board | C Resilient Bar |
| B Steel Lattice Truss | D 12.5mm Plasterboard |

Figure 5: 30-minute domestic truss floor with a single layer of appropriate plasterboard as per Table 3.

The chosen floor sheeting is to be fixed to the floor trusses using self-drill/self-tap screws at max 300 centres internally and 150mm centres around the perimeter for diaphragm action.

Where trusses are supporting load bearing walls overhead, web stiffeners are fitted as required for structural stiffness to support the loads tracking from above to avoid crushing. Floors are not allowed to run through the party wall (separating wall).

2.1.6 Roof Structure

The roof trusses can be either a traditional timber cut roof or prefabricated roof truss made from timber or steel. The site fitted roof trusses are attached to timber wall plates, which are bolted on site to the top wall track of the load bearing Vision Built wall panel. Vision Built cold formed roof trusses can be fixed down directly with a thermal break onto the top wall track of the load bearing Vision Built wall panel.

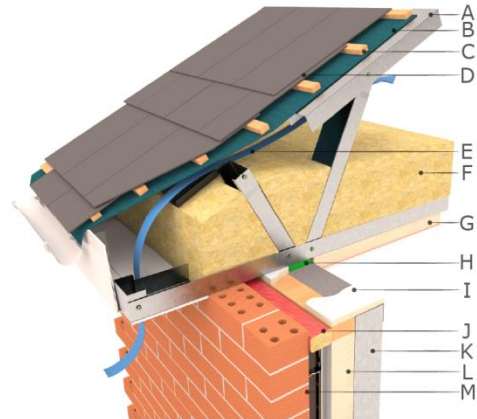

- | | |
|------------------------------|-------------------------------------|
| A Steel Truss | H Thermal Break |
| B Roofing Felt | I Insulation |
| C Timber Batten | J Cavity Barrier |
| D Roof Tile | K Steel Stud |
| E Ventilation | L P.I.R./Phenolic Insulation |
| F Rockwool Insulation | M External Masonry Wall |
| G Ceiling Board | |

Figure 6: Cold roof eaves detail with thermal break at wall plate

Typically roof trusses are aligned with the wall studs of the story below. In situations where the roof truss does not align with the wall studs, a top track beam is provided across the top of the wall studs to allow the roof truss load transfer to the wall studs. Figure 6 and Figure 7 show typical eaves detail for a cold roof with both steel and timber roof truss fixed in position.

Roofs may be clad with concrete or clay interlocking tiles or slates imposing a load not exceeding 0.55kN/m².

2.1.7 Chimney Construction

Vision Built Steel Frame Building System can incorporate both traditional block/brick chimney construction or an NSAI Agrément approved pre-fabricated chimney system in accordance with its NSAI Certificate and the Building Regulations.

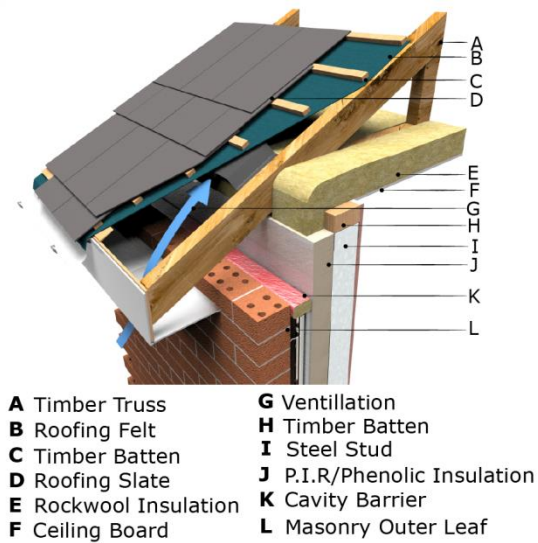

Figure 7: Cold roof eaves detail with timber trusses

2.1.8 Internal Linings and Finishes

Linings to walls and ceilings are of plasterboard of Type F as specified in Table 4, manufactured to IS EN 520:2005 *Gypsum plasterboard. Definitions and test methods*. They are attached by means of self-drill/self-tap screws into steel members. In areas prone to high levels of humidity, moisture resistant plasterboard should be used. Joints in plasterboard can be taped and filled in accordance with the plasterboard manufacturers' instructions for direct decoration. Alternatively skim coat plaster can be applied. Any wall mounted fitting to the wall other than lightweight items, e.g. framed pictures, must be fixed into a vertical stud behind plasterboard using appropriately sized proprietary fixings. The fixings should be appropriate for fixing to 2-3mm LGS. To accommodate larger wall mounted fittings such as kitchen units, timber grounds can be provided between LGS studs. Figure 8 illustrates a typical timber ground between studs in an internal wall to provide support for a socket.

2.2 GENERAL BUILDING STRUCTURE

2.2.1 Foundations

Foundations are outside the scope of the certificate. Based on finalised layouts, the Vision Built structural engineer can carry out a load take down calculation and provide the client appointed structural engineer with accurate line loads which they can accommodate into their foundation design.

Vision Built Steel Frame Building System may be used with a variety of foundation types, depending on the ground conditions encountered on site. A site investigation should be carried out by an appropriately qualified and experienced engineer to determine the maximum bearing pressure the soil can carry. Once this is established a suitable foundation type can be selected. A tolerance of $\pm 5\text{mm}$ in 10 meter

lengths is specified for both concrete slab level and horizontal dimensions. Where variations in slab level occur, such variations are catered for using galvanised steel spacers or thermally broken (shims) located directly below the studs as required. However, the use of such shims should be kept to a minimum. The remaining gaps below the steel frame panel sole plate are filled using structural grade non-shrink grout.

Note: The construction of the foundations and ground floor slab are the responsibility of the main contractor, and should be constructed in accordance with the Client's engineering specifications. Due to the low tolerances of the steel frame manufacture, the foundation and ground floor slab must be constructed accurately, i.e. correct dimensions, square and level so that the steel frame system can be assembled and erected properly within the specified tolerances.

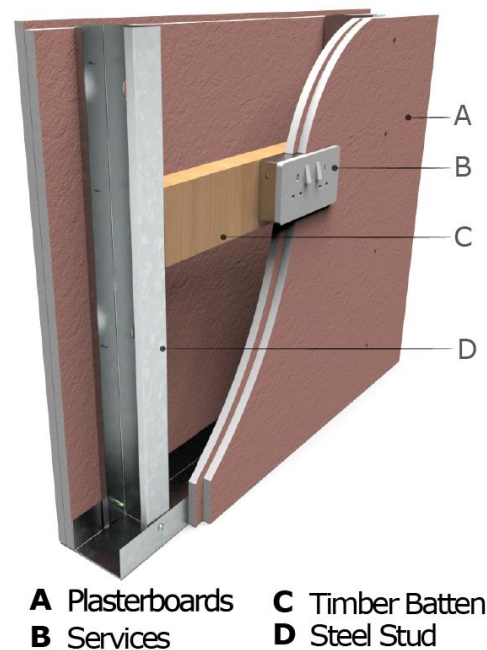

Figure 8: Typical Grounds for Services

2.2.2 Ground Floor

An in-situ concrete slab may be used to form the ground floor. Below the concrete slab, insulation is provided to meet the requirements of TGD to Part L of the Building Regulations, including the avoidance of cold bridging. An NSAI or equally approved radon resistant membrane is installed in accordance with Clause 8 of IS EN 1996-1-1:2005 Eurocode 6 and BS 8102:2009 *Code of practice for protection of below ground structures against water from the ground*, to protect the floor and bottom channels of the steel studs from rising damp. Alternatively, a proprietary suspended ground floor may be used, provided it is approved by the Vision Built Structural Engineer for use with

the Vision Built Steel Frame Building System to meet the required structural loads criteria (dead load, uplift, etc.). The structural design of the ground floor should be in accordance with Part 3 of this Certificate.

2.2.3 Concrete Podium Slab (Transfer Slab)

Where the Vision Built Steel Frame Building System is constructed off a concrete podium slab, a tolerance of $\pm 5\text{mm}$ is required on the podium slab line and level. Procedures for variations in slab are as described in Section 2.2.1 above. The construction of the podium slab is the responsibility of the main contractor and the design is the responsibility of the client’s engineer, who will require line loads from the Vision Built Structural Engineer. Vision Built Structural Certification applies from transfer slab level upwards.

2.3 DESIGN AND MANUFACTURE

2.3.1 Design Process

Before a Vision Built Steel, Frame Building can be manufactured a Chartered Structural Engineer must complete the structural design including the specification of all members. The client’s architectural drawings are received by Vision Built and converted into a 3D structural computer aided design model (CAD/CAM). This system automatically calculates all framing requirements for walls, floors, roof trusses, and allows for all openings such as doors and windows. Each individual frame member is allocated a unique identification number and has its length calculated, along with the position of any cut-outs, punch holes or bracket positions. The Vision Built Structural Engineer checks and signs off all drawings to ensure structural compliance before any drawing are transferred to production. Once the drawings have been cleared for production they are transferred to the computer which operates the roll-forming equipment.

Elements	Tolerance
Length	$\pm 2\text{mm}$ in 10m lengths
Opening position	$\pm 2\text{mm}$
Size of openings	+5mm -0mm
Frame squareness	$\pm 2\text{mm}$

Table 1: Manufacturing Tolerances

2.3.2 Roll-Form Production

The roll-formers use computer aided manufacturing (CAM) techniques to process the data, which has been transferred from the design office to the roll former. The steel coil is then formed into the required shapes, with the position of cut-outs, punch-holes etc. being accurately located within a tolerance of $\pm 2\text{mm}$ per 10m length. Individual members are grouped into bundles as they come off the roll-forming

equipment, corresponding to their subsequent handling in the assembly process. Assembly of the components can commence in the factory directly after it has been roll-formed or the components can be transferred in flat pack form for assembly elsewhere by Vision Built approved installers.

2.3.3 Wall Panel Assembly

The steel frame panels are composed of galvanised mild steel manufactured from galvanised coil as described in Section 2.4.2. All profiles are designed in accordance with IS EN 1993-1-3 Eurocode 3: *Design of Steel Structures - Part 1-3: General Rules - Supplementary Rules for Cold-Formed Members and Sheeting*. Section properties comply with IS EN 10162:2003 *Cold Rolled Steel Sections - Technical Delivery Conditions - Dimensional and Cross-sectional Tolerances*. The wall panels have vertical, C-channel studs at maximum 600mm centres, which are fixed to top and bottom horizontal channels using self-tapping screws. The screws are precisely located in pre-punched holes in the studs, which match holes in the top and bottom channel. The pre-punched holes in the studs are dimpled which allows the flat-topped self-tapping screw to be flush with the metal surface. These dimples also mate with the dimples in the horizontal channel, which increase the shear strength of the joint.

2.3.4 Floor Cassette Assembly

The use of floor cassettes is project specific, with cassettes often being used for mid-rise multi-storey buildings.

Floor cassettes are factory assembled and delivered to site. The components of the floor cassette are connected using self-tapping screws. A floor decking is screwed to the top of the cassette and the joints glued.

The floor cassettes are either hung on Z-hanger end tracks that are connected to the supporting walls or the platform floor cassettes sit between the walls. The solution adopted is chosen by the project structural engineer.

2.3.5 Quality Control Production

Quality control carried out during manufacture includes visual inspection of steel coiled raw material, calibration of roll forming equipment daily, cross checking of all in-house production drawings, and checks on production dimensions (length, width, and steel thickness) and on the dimensions and squareness of finished panels. Each panel is labelled with a QC sticker confirming it has passed final inspection. Vision Built operates a full in-house quality control system, which outlines procedures on material specification, quality control in production, purchasing of raw materials, design and assembly.

2.4 STRUCTURAL PRINCIPLES

2.4.1 Steel Frame Structure

The basis of the typical Vision Built structure is a cold-formed light gauge steel frame, which is assembled into units in the factory and installed on site. The design, manufacture, assembly and erection of the system is based on the combined services of BIM (Building Information Modelling) and CNC software, which feeds the required code into the proprietary roll-formers and produces the documentation required to manufacture and install accurately.

The panels are fabricated from suitably coated steel coil as described in section 2.4.2 which is formed into the required shapes by proprietary roll-forming equipment. The frequency and size of the structural elements will depend on the individual panel and truss design. The individual elements manufactured are then assembled by trained personnel on the floor to produce the required wall or truss required with fixings as specified by the structural engineer.

The wall panels will also have ancillary elements assembled into the panel such as strap or 'K' bracing, lintel trusses over openings and rigid insulation on the external walls which are described in this certificate.

Typically, when it comes to traditional roofs, prefabricated timber roof trusses are typically utilised in Vision Built structures where required. Timber Roof trusses are designed and supplied by others. However, there are occasions where the roof truss is supplied as a cold rolled truss system designed and manufactured by Vision Built. This would be produced using the typical sections produced by Vision Built and the fixings specified by the structural engineer.

The grades of steel and dimensions of sections used are selected and specified by a Vision Built Chartered Structural Design Engineer in accordance with design requirements. Table 3 shows typical section sizes utilised for both load bearing walls and trusses for the cold formed steel elements of their system.

Section properties are calculated using design core thickness of steel (excluding coatings) in accordance to IS EN 1993-1-1 NA: 2007 *Design of steel structures – Part 1.1: General rules and rules for Buildings*, IS EN 1993-1-3 and IS EN 1993-1-5 NA: 2010 *Design of Steel Structures – Part 1-5: Plated Structural Elements*.

2.4.2 Protective Coatings

The steel frame members are all coated with a protective zinc-rich metal coating. The steel frame members are manufactured from galvanized coil steel to IS EN 10346:2015, *Continuously Hot-dip Coated Steel Flat Products for Cold Forming* -

Technical Delivery Conditions, (min. yield stress 350 N/mm²) with 275 g/m² zinc protection. All cold formed section properties are calculated using design core thickness of steel (excluding coatings) in accordance to IS EN 1993-1-1 NA:2007 and IS EN 1993-1-5 NA:2010.

In additions to the steel members in the system being protected by zinc rich protective coatings, further protection against corrosion and longer design life is given to the steel by providing the following:

- The bottom channel on all ground floor steel frame panels is additionally protected by a 100mm wide DPC from the floor slab.
- The rigid board insulation keeps the steel in a "warmframe" environment, which, in conjunction with the external breathable membrane and internal air tight barrier, prevents the formation of condensation within the wall structure.
- The metal and timber in the roof trusses is kept free from prolonged moisture build up, by means of free air circulation in the roof space, using ventilation methods in accordance with Part F2 of TGD to Part F of the Building Regulations.
- Where steel is cut on site or where the coating of the steel becomes damaged, it is protected by the application of a zinc rich paint.
- All fasteners have been assessed and tested for use with the system, to ensure the minimum 60-year design life of the system.

Component Type	Grade of Steel	Typical Section Dimensions			
		Depth (h)	Width (b)	Lip (c)	Thickness ¹ (t)
Wall Stud/Lattice truss	S350 S390 S450	89	46	10 - 12	0.96 - 1.96
Wall Stud/Lattice truss	S350 S390 S450	100	46	10 - 12	0.96 - 1.96
Wall Track/Noggin ²	S350 S390 S450	90	46	0 - 10	0.96 - 1.96
Wall Stud	S350 S390 S450	150	50	0 - 12	1.16 - 2.46

¹ The range of thickness of cold formed section available = 0.8, 1.0, 1.2, 1.5, 2.0, 2.5mm.

² Range of Depth (h) and Width (b) available to allow for uniform cross section of structural zone.

³ These profiles are standard; other special profiles are available on request.

Table 2: Typical Sized of Elements in the Steel Frame System

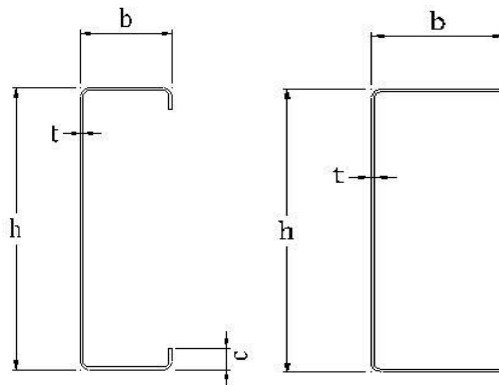

Figure 9: Channel with and without Lip

2.4.3 Fasteners and Connection Joints

The unique design of the Vision Built Steel Frame Building System allows for no welding of joints in the system. The system is assembled using fasteners such as self-piercing rivets, screws or bolts. All fasteners used in the steel frame system are adequately protected against corrosion i.e. galvanising/zinc coating and made from a suitable metal to ensure the design life of the system is maintained. Vision Built provide a full specification of all fasteners, where they are to be used and how they are to be installed during the construction of the system. Only system fasteners approved or supplied by Vision Built may be used with the system. It is important to ensure that protective coatings on fasteners are not removed, i.e. to assist the fitting of a connection, as this would severely compromise the corrosion performance of the fastener. Where a building is located within one kilometre of the coastline and has a steel roof, all fasteners at the eaves shall be coated with a zinc rich paint to protect against coastal spray or fasteners used that have the required salt spray test for this application.

2.4.4 Load Bearing Walls Structural Principles

The perimeter walls can be the primary load bearing elements of the structure and are therefore designed to bear on the walls of the panels below, i.e. permanent and variable imposed loads are transferred by load bearing external wall panels and if required load bearing internal wall partitions where necessary.

The load bearing wall panels are comprised of vertical studs, fixed to horizontal head and bottom channel sections. Horizontal noggins are fitted at the mid-height of all panels where required to provide additional strength and where particularly high vertical loads occur. Studs can interlock together to form box sections as required under high concentrated loads. Typically, roof trusses are aligned with the vertical studs, which in turn are aligned above studs in the wall below. Where windows are present or where roof trusses change centres a cold formed lintel or hot rolled section is provided to allow the load to transfer to the vertical wall studs. The design loads from each level are transferred through the primary load

bearing elements into the substructures / foundations. Perimeter steel Z or C sections can be used to support floor joists before permanent fixing and can also be designed to act as a lintel over openings.

HRS (Hot Rolled Steel) structural members may also be incorporated into the design of the wall panels as required to accommodate more complex structural designs. Any HRS structural members used as part of the Vision Built Steel Frame Building System must be fabricated in accordance with IS EN 1090-1:2009 *Execution of Steel Structures and Aluminium Structures Part 1: Requirements for Conformity Assessment of Structural Components* and in accordance with execution class specified in the project specific design. Figure 9 shows a HRS beam protected by plasterboard supporting a composite concrete steel separating floor.

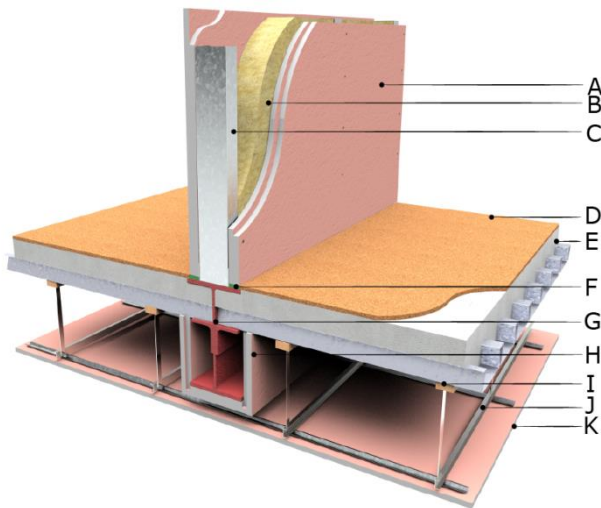

- | | |
|------------------------------|------------------------------|
| A Plasterboard | G Hot Rolled Steel |
| B Rockwool Insulation | H Plasterboard |
| C Steel Stud | I Timber Batten |
| D Cork Boarding | J Suspended Ceiling |
| E Composite Deck | K 12.5mm Moisture Res |
| F Acoustic Sealant | |

Figure 10: Illustrates integration of (HRS) structural steel with Light Gauge Steel to provide additional strength.

2.4.5 Racking

Resistance to horizontal loading (racking) is provided by the horizontal diaphragm action of the approved floor sheeting and roof in conjunction with the metal diagonal cross-bracing members on specific external inner leaf and internal walls. All cross bracing is pre-assembled in the factory and has the dual function of ensuring squareness of factory produced panels in addition to providing lateral stability for the overall structure. Vision Built use both strap and K bracing.

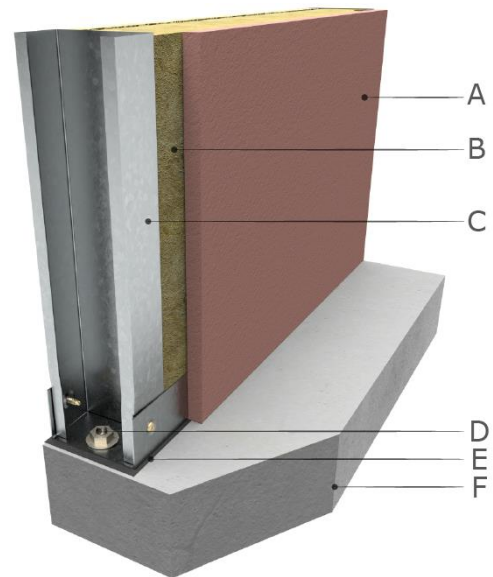

- | | |
|------------------------------|------------------------|
| A Plasterboards | D Anchor Bolt |
| B Rockwool Insulation | E DPC |
| C Steel Studs | F Concrete Slab |

Figure 11: Typical Fixing Detail of Bottom Channel to Concrete Slab with Proprietary Anchor Bolt

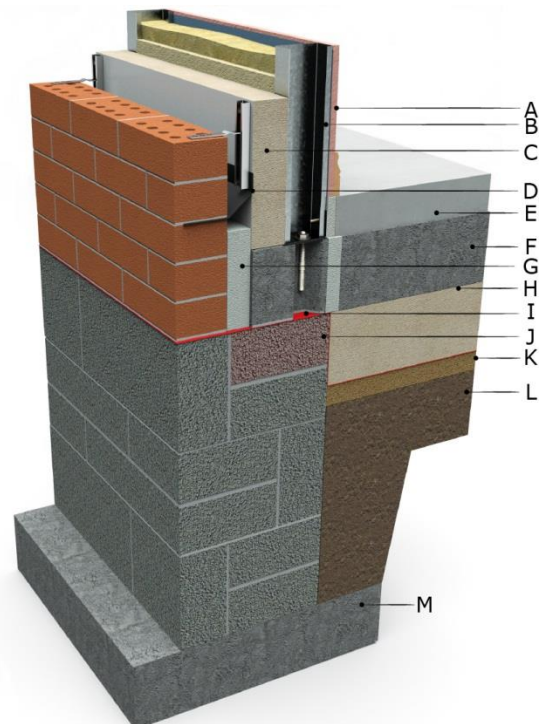

- | | |
|-------------------------------------|------------------------------|
| A Plasterboard | H Floor Insulation |
| B Steel Stud | I Radon Barrier |
| C P.I.R./Phenolic Insulation | J Thermal Block |
| D DPC | K Sand |
| E Screed | L Hardcore |
| F Suspended Concrete Slab | M Concrete Foundation |
| G Styrofoam | |

Figure 12: Detail of Steel Frame Connected to Blockwork rising wall

2.4.6 Holding Down

To provide resistance to uplift, the bottom channel of the external panels is fixed to the ground floor slab, podium slab or rising wall with anchor bolts. The type of anchor bolt used to hold down the external panels of the system will be dependent on what substrate the anchor is being fixed to. These post fixed anchors are designed by Vision Built Structural Engineer and are installed in accordance with the *Code of Practice for the Design and Installation of Anchors in accordance with section 60 of the Safety, Health and Welfare at Work Act 2005*. The positions of the anchors are project specific and are determined by Vision Built's Chartered Structural Engineer and are factory positioned in the bottom channel member.

Figure 11 shows the preferred option of fixing the steel frame bottom channel to a reinforced concrete slab with a proprietary anchor. In addition to the internal leaf of the external wall being fixed to the foundation all internal panels on the ground floor are fixed to the concrete slab with proprietary approved anchors. The plasterboard is site applied allowing access for the anchor to be installed on site.

Figure 12 illustrates the detail of fixing the steel frame to a concrete block rising wall.

2.5 COMPARTMENTATION

2.5.1 Separating Wall (Party Wall)

Separating walls (party walls) are constructed using a minimum of two independent cold formed steel framed leaves (studs at 600mm centres max.) two layers of 15mm gypsum soundbloc or two layers of 15mm type 5 plasterboard internal lining on each side, fixed with the joints staggered. This cavity is then full filled with stone mineral wool batts of minimum 24kg/m³ density. These wool batts are continuous from ground floor to the upper floor ceiling level and provide the required acoustic properties.

Where the attic space is habitable the mineral wool fibre must go up to the underside of the roof for acoustic purposes. Where the party wall abuts an external wall, the mineral wool within the cavity of the party wall extends through the inner leaf of the external wall and abuts the cavity closer as shown in Figure 13 and Figure 14, respectively. This detail seals air gaps and minimises flanking sound transmission.

At the junction of the compartment floor and the party wall, an additional 500mm section of mineral wool insulation is provided within the cold formed section zone each side of the cavity mineral wool to minimise flanking and direct sound transmission and provide additional fire protection. The head of the party wall must also be fire stopped and cavity closed as specified by

the Vision Built construction details. Where services are required in a party wall, they can be accommodated by additional dry lining to the party wall with battens and plasterboard. All Battens used with the Vision Built system are treated in accordance with BS 8417:2011 +A1:2014 *Preservation of wood. Code of practice*. Design must comply with the requirements of Section 3.5 of TGD B 2017 Volume 2 of Building Regulations for purpose class 1(a), 1(b) & 1(d) and in accordance with Section 3.2.5 of TGD B 2006 of Building Regulations for all other purpose classes to which this certificate applies.

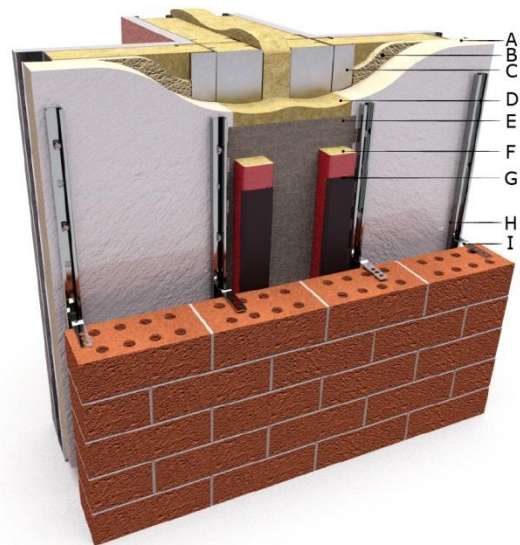

- | | |
|------------------------------------|---------------------------------------|
| A P.I.R/Phenolic Insulation | F Cavity Barrier |
| B Closed Cell Insulation | G DPC |
| C Steel Stud | H Stainless Steel Wall Channel |
| D Rockwool | I Rockwool |
| E Breather Membrane Tape | J Masonry Outer Leaf |

Figure 13: Party wall detail (Option 1) at junction with external masonry wall

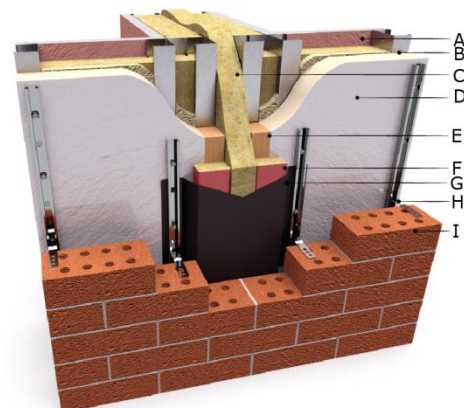

- | | |
|------------------------------------|---------------------------------------|
| A Plasterboard | F Cavity Barrier |
| B Steel Stud | G DPC |
| C Rockwool | H Stainless Steel Wall Channel |
| D P.I.R/Phenolic Insulation | I External Masonry Wall |
| E Timber Batten | |

Figure 14: Party wall detail (option 2) at junction with external masonry wall

2.5.2 Single Frame Compartment Walls

A compartment wall within the Vision Built Steel Frame Building System can be constructed of a single steel frame wall. This wall can be used in situations where a building is sub-divided into different compartments but this compartment wall **must not** be used where a wall is common to two or more buildings (separating wall) or where a compartment wall is used to separate dwellings from each other within a building. The single frame panel must be designed and specified to meet the acoustic, fire and structural requirements required by the wall within the building to meet the requirements of TGD B Volume II of Building Regulations for purpose class 1(a), 1(b) & 1(d) and TGD B 2006 of Building Regulations for all other purpose classes to which this certificate applies.

No services are allowed within the compartment wall and where services are required in a compartment wall, they can be accommodated by battening out the wall with timber battens or with resilient bar similar to accommodating services in a party wall. Services however can pass through a compartment wall but they must be appropriately protected in accordance with the recommendations in be in accordance with Section 3.5.4.1 of TGD B 2017 Volume 2 of Building Regulations for purpose class 1(a), 1(b) & 1(d) and in accordance with Section 3.2.5.7 and 3.4 of TGD B of Building Regulations for all other purpose classes to which this certificate applies. Services passing through compartment walls should be kept to a minimum and avoided where possible.

2.5.3 Compartment Floors

The compartment floor can be designed to provide 60 or 90 minutes' fire resistance from the underside. There are two forms of compartment floors used with the Vision Built Steel Frame Building System:

- Steel Lattice Joist protected with Plasterboard.
- Steel Concrete Composite Deck.

2.5.3.1 Compartment Floor Steel Lattice Joists Protected with Plasterboard

The structure of a compartment floor used with the Vision Built Steel Frame Building System consists of 200mm to 350mm deep cold formed steel lattice joists, Figure 15.

Electrical installations and recessed lights **cannot** be accommodated within a compartment floor. All electrical installations must be accommodated by creating a separate service void under the compartment floor all installed services must be in accordance with Section 3.5.4.1 of TGD B 2017 Volume II for purpose class 1(a), 1(b) & 1(d) and in accordance with Section 3.2.5.7 and 3.4 of TGD

B 2006 for all other purpose classes to which this certificate applies. Services may be surface mounted or accommodated in service ducts or within service cavities created external to the unbreached linings of the fire-resistant compartment floor.

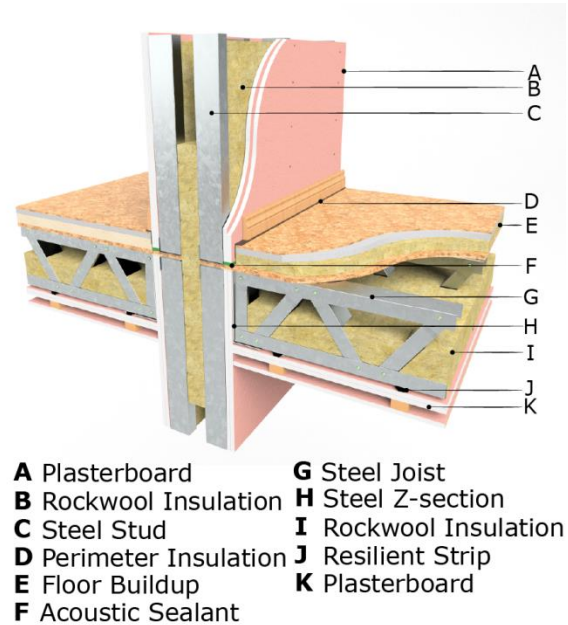
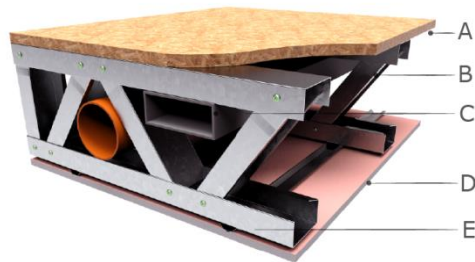

Figure 15: Truss compartment floor junction

Mechanical Ventilation extraction ducts are allowed to pass vertically through the floor but must be appropriately fire sealed where they enter and exit and comply with the recommendations contained within BS 9999:2017 *Fire Safety in the Design, Management and Use of Buildings - Code of practice*. Where pipes pass through a compartment floor (unless the pipe is in a protected shaft) they should comply with section 3.5.4.1 of TGD B 2017 Volume 2 of Building Regulations for purpose class 1(a), 1(b) & 1(d) and in accordance with Section 3.2.5.7 and 3.4 of TGD B 2006 of Building Regulations for all other purpose classes to which this certificate applies.

100mm of mineral wool insulation is installed between each cold formed lattice truss for additional acoustic performance. A resilient layer provides acoustic properties to ensure compliance with the requirements of Part E of the Building Regulations. Further improvements to acoustic reductions can be achieved by using resilient bars between the ceiling cassettes and the plasterboard. Each 22mm sheet of plywood floor sheeting is placed such that the joint in the sheets are staggered and each sheet is individually screwed at each cold formed lattice truss location. The first sheet of OSB board is run over the supporting wall and fixed as required to the head beam of the wall (Figure 15).



A 18mm OSB Board **D** 12.5mm Plasterboard
B Steel Lattice Truss **E** Resilient Bar
C Steel Studs

Figure 16: Joist Floor with Services in Trusses

Where a lattice type floor is supplied as a non-compartment floor, services can be catered for through the lattice diagonals as illustrated in Figure 14. However, if these services enter compartment walls or floors, the penetrations need to be adequately fire stopped.

2.5.3.2 Compartment Floor Steel Concrete Composite Deck

The floor is constructed of a composite profiled metal deck which is fixed to the head track of the supporting load bearing walls; reinforcement bars and in-situ concrete are added to the deck as required by design. An additional layer of resilient material is added to the top of the composite slab to meet the requirements Floor Type 1 (Figure 17) and Type 2 (Figure 18) as outlined in Section 4.4 of TGD to Part E of the Building Regulations. The underside of the deck is fitted with 12.5mm moisture resistant plasterboard.

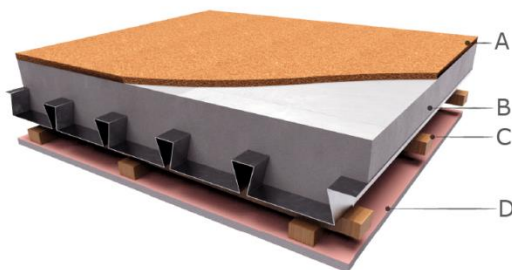

A Cork Boarding **C** Timber Batten
B Composite Deck **D** 12.5mm Moisture Res Board

Figure 17: Resilient material bonded to concrete Slab (TGD E Type 1 Floor)

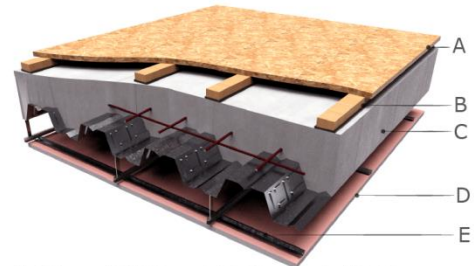

A 18mm OSB Board **D** Suspended Ceiling
B Timber Batten **E** 12.5mm Moisture Res Board
C Composite Deck

Figure 18: Floor Treatment on Concrete Floor Slab, Ceiling provided to underside of Concrete Slab (TGD E Type 2 Floor)

2.5.3.3 Fire Resistance of Steel/Concrete Composite Deck

The fire resistance of the composite deck is provided from the underside of the deck. The composite deck can provide up to 90 minutes' load bearing fire resistance from a combination of the bars within the trough of the decking and adequate concrete cover to the bars in question.

The 12.5mm moisture resistant plasterboard will provide additional fire protection but is not considered in the fire resistance performance. The composite deck compartment floor is suitable for buildings of purpose class 2(a) and all other purpose classes to which this certificate relates (2(b), 3, 4(a) and 5).

The composite deck compartment floor has not been assessed for use for purpose groups 1(a), 1(b) and 1(d) of TGD B Fire Safety Dwelling Houses Volume 2 of Building Regulations.

All electrical and ventilation services are installed to the underside of the deck. The fire stopping of holes in the composite deck floor slab to accommodate pipes passing through a compartment floor (unless the pipe is in a protected shaft) should comply with Section 3.4.2 of the TGD to Part B 2006 of the Building Regulations.

2.5.4 Forming Holes in Profiled Decks

When holes or opes to accommodate service penetrations are required, these can be incorporated in the composite concrete slab design prior to pouring the structural concrete. When additional opes are required, the size and exact location must be signed off by the structural engineer who designed the concrete slab.

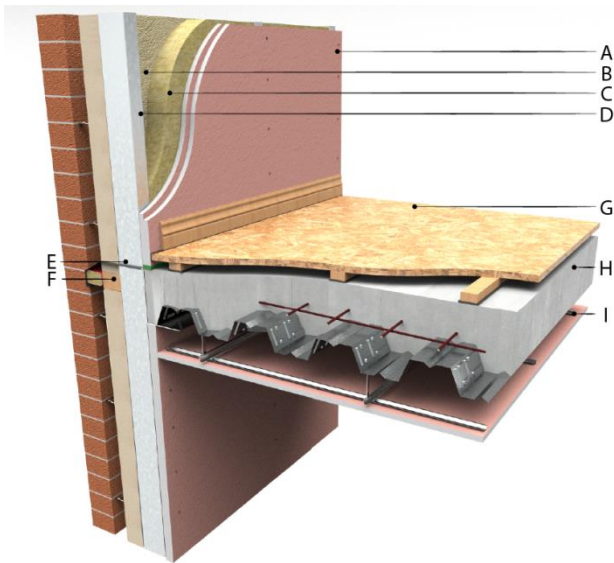

- | | |
|---------------------------------|----------------------------|
| A Plasterboard | F Cavity Barrier |
| B Closed Cell Insulation | G OSB Board |
| C Rockwool | H Composite Deck |
| D Steel Stud | I Suspended Ceiling |
| E DPC | |

Figure 19: Steel concrete composite deck compartment floor junction with external wall with cavity barrier

2.5.4 Exposure of Metal Decks

Steel concrete composite decks are intended for internal use within the building envelope. Where design requires the metal deck to be exposed to the external environment, such as in a balcony situation, the metal deck needs to be thermally insulated to provide required u-value and limit thermal bridging. In addition, it should be suitably weather protected in accordance with the project specific design.

2.5.5 Cavity Barriers and Fire Stops

To meet the requirements of TGD to Part B of the Building Regulations, the correct specification and placement of cavity barriers and fire stops shall be detailed and shown on a schedule for the project. Typically, cavity barriers and fire stops should be provided in the construction of steel frame walls as follows:

- Separating walls shall have a vertical fire stop sealing the cavity at the wall ends, running from DPC level to the underside of the fire stopping at the top of the wall.
- At a separating wall junction with the external wall, vertical cavity barriers shall be placed in the external wall on either side of the separating wall junction (Figure 12).
- An alternative approach where a vertical fire stop across the full width of the party wall is used in the external wall as well as a fire stop in the separating wall ends (Figure 13). The fire stop must be in compression and tightly sealed to the external wall cavity.

- Horizontal fire stops shall be placed within separating walls (and double leaf compartment walls) at all floor levels and (unless cavity barriers are appropriate) at roof ceiling level. The fire stops shall extend the full length of the separating/compartment wall and shall tightly abut the rear of the vertical fire stops at the ends of the separating/compartment wall and the non-combustible board at the top of the separating/compartment wall. These fire stops shall cover the full floor depth as well as the bottom rails of the upper wall panel and the head plates of the lower wall panel.
- A fire stop shall cover the full ceiling depth as well as the upper wall panel rail and lower wall panel head plate.
- Eaves boxes shall be provided at the junctions of separating wall and compartment walls with external walls to reduce the risk of fire passing across these junctions.
- Cavity barriers are required around all openings in external walls such as doors, windows, vents, extractor fans, meter cupboards, etc.

Figure 6, Figure 7, Figure 13, Figure 14 and Figure 19 show typical details on the proper installation of cavity barriers and fire stops in the Vision Built Steel Frame Building System.

2.6 DELIVERY, STORAGE AND SITE HANDLING

2.6.1 Delivery of Panels

The frame panels are delivered to site in packs that can be off-loaded by mechanical means or by hand. Where lifting points are required, they are located, designed and certified by the structural engineer, taking into account the unit weight and dimensions and the distance of lift required. They will conform to the requirements of the Safety, Health and Welfare at Work Act 2005 and the Safety, Health and Welfare at Work (Construction) Regulations 2013. All off-loading and erection should be in accordance with the Vision Built Method Statement and erection procedures. Erection tools such as spanners and drill bits should be of suitable quality to avoid surface contamination.

All lifting shall be carried out by competent personnel in accordance with the Vision Built Erection Manual and site-specific safety statement. Care is needed to avoid scratching the surface of any exposed steel frame members or contamination from carbon steel during pick-up.

The use of protective gloves when handling the LGS panels is necessary, as steel members formed from cut or sheared sheet can have sharp edges and care should be taken when handled, to avoid injury. The exposed steel frames members must be kept out of contact with dry cement and lime.

Frame paned are transported vertically on stillages or similar sized panels can be stacked horizontally using timber skids, prior to strapping down and transporting to site. In general, panels are craned into position, large panels require designed lifting pins while smaller panels may be manually manoeuvred into position.

Frames must be stored on a dry, clean, level base with a suitable packing to prevent damage and must not be dropped or allowed to rest on projecting objects. Panels are lifted in a sequential manner with a mechanical lifting device. The maximum weight of any single panel should not be more than 200kg. Larger panels will require mechanical lifting.

Flooring and other ancillary items such as insulation and fire stops must also be kept dry and stored on a firm level base.

2.6.2 Traceability

The Vision Built System uses a specifically designed barcoding system which ensures full traceability can be achieved between design, production and site assembly. Steel coils delivered to the factory are labelled with a barcode which is scanned when the coil is loaded to the roll forming machine. This ensures panels produced can be traced to individual coils of steel. Each assembly drawing also contains a unique barcode. This barcode is scanned at the roll forming station, panel assembly station, insulation station and dispatch station. Each time the barcode is scanned, information is automatically updated on a traceability program designed by the company. All production and design information for each individual panel can be accessed using this system if required. Site assembly drawings also use this barcode reference so that each panel can be unloaded to the relevant part of the site and can be easily identified for site installation. The first letter of the barcode also signifies the end use of each panel. Barcodes which begin with the letter E are external walls, I are internal walls and P are partition walls.

2.6.3 Typical Material List Supplied to Site

With each customised delivery to site, a comprehensive bill of materials is supplied. This bill of materials gives a detailed list of all components delivered to site to complete the installed steel frame building. All panels are individually numbered using the pre-marking system during production to correspond with the erection drawings supplied with the bill of materials. This pre-marking system gives the advantages of both speed and accuracy during assembly and erection on site.

2.6.4 Main Contractor Responsibilities

The main contractor is responsible for the proper construction of the foundations, ground floor slab

or podium slab within the tolerances specified by Vision Built. Once the floor slab is within the tolerance range, erection of the Vision Built Steel Frame Building System can commence. If floor is outside the specified tolerances when Vision Built arrives on site to commence erection, the remedial works (grinding etc.) will be the responsibility of the Main Contractor. When the panels are completely erected brick/block laying trades can commence. The main contractor on site is responsible for providing scaffolding and site-specific fall arrest to wall plate level and all access necessary for the safe erection of the structure. Vision Built also provide the main contractor with project specific building details on the construction of their steel frame system.

2.7 INSTALLATION

2.7.1 General

Installation is carried out in accordance with the requirements of this Certificate and all relevant codes of building practice, regulatory Health & Safety requirements and the manufacturer's instructions contained in the Vision Built Installation Manual, a copy of which must be available on each site. Site erection must only be carried out by a Vision Built approved installer or a specialist sub-contractor under the supervision of Vision Built and in accordance with the Vision Built Installation Manual. Installers are approved once they have undergone on-site training, understand the fundamental structural principles of the system, fire stopping requirements, tolerances, importance of weathering, storage and handling of the panels and all other relevant information. Installers should have installed panels under the guidance of a qualified installer and have a signed record of this training. All off-loading and erection should be in accordance with the Vision Built Method Statement and erection procedures. Care must be taken to avoid any damage to the steel frame components during lifting and connecting brackets during transportation and installation.

To achieve adequate protection from ground moisture, a continuous damp proof membrane (DPM) must be included at foundation level. If the site location necessitates the provision of a radon barrier, a correctly installed radon barrier will also act as a DPM.

All structural connections to the foundation must be installed in accordance with the structural design details, independently checked by qualified members of the installation team and formally recorded on the Vision Built site quality control records.

It should be noted that, as outlined in Figure 10 and Figure 11, the DPC is penetrated with the holding down bolts for the system however, the DPM and radon barrier (which often acts as the

DPM) is not penetrated. As the DPC is installed as an element of good practice, as opposed to an essential construction element, there is no risk to the system if the holding down bolts penetrates the DPC.

2.7.2 Site Supervision

The approved installation contractors are subject to supervision by the Vision Built site manager. Typically, the Vision Built site manager will agree a schedule of inspections with the erection contractor. The supervisor of the erection crew is responsible for the quality and productivity of work carried out by the erection crew. The erection supervisor reports directly to the Vision Built site manager to ensure all work follows the requirements of the design drawings and the requirements of Vision Built Structural certification for the building.

Vision Built employ a full-time site manager who works very closely with the erection supervisor, and the main contractor responsible for providing the concrete substructure. The site manager is responsible for ensuring all concrete slabs are within the engineer's specified tolerances before panels are installed on site. No panels are installed until the Vision Built site manager approves the concrete base that the panels are being fixed too. All fixings and brackets between panels are visually inspected, periodically photographed and recorded on the assembly quality control sheet for structural connections. Each building has its own quality control sheet for structural connections, which is kept on site by the Vision Built site manager. The site manager also inspects fire stopping and cavity closing of all panels, service shafts and then records this information on the fire stopping within the Vision Built steel frame check sheets which are recorded for each floor of each building. Any defects noted are recorded, photographed where possible and notified in writing to the erection supervisor. The site manager will inspect and approve the remediation before work can proceed.

The approved steel frame erection contractors are subject to continuous supervision by the Vision Built site manager. The following checklist is provided to offer guidance to clients who intend to carry out their own additional site supervision. The items listed are of a general nature and are in addition to all other building requirements.

- All components delivered to site comply with the Bill of Materials.
- Components are not damaged and are properly pre-marked for erection.
- The substructure is set out accurately and level within the tolerance specified by Vision Built before the wall panels are positioned.
- The steel frame should not be erected unless any inaccuracies in the floor slab have been corrected.
- The ground floor layout is properly marked out.
- DPC and DPM are correctly installed in accordance with BS 8102:2009
- DPC course is laid under all ground floor panels, as a good practice measure between steel and concrete, both internally and externally.
- Panels are in line and plumb and in accordance with the Vision Built panel layout.
- Rooms are checked for squareness.
- All ground floor steel frame panels are correctly anchored into position (penetrating the DPC but not penetrating the DPM) in accordance with the erection drawings.
- All insulated wall panels are free from damage after erection.
- All horizontal and vertical joints are correctly detailed.
- All bottom tracks are free of construction debris.
- Wall ties are correctly spaced and positioned.
- Horizontal DPCs are correctly turned up against the bottom channel upstands as dry lining proceeds.
- Joints in floor decking occur on the centre line of the joists and all T&G joints run perpendicular to the floor trusses. Decking sheet joints must be staggered.
- If floor is exposed to weather for prolonged periods then it will need to be protected with a weatherproof cover.
- Floor is screwed at the correct centres i.e. 150mm at openings, edges and 300mm everywhere else.
- Grommets are installed where necessary in service holes as per Vision Built drawings.
- All bracing is properly tensioned.
- Check for requirement of web stiffeners when floor joists/truss are continuous over internal load bearing support walls against Engineers drawings.
- Cavity barriers and fire stops are installed as specified and in accordance with the Building Regulations.
- Roof trusses are installed plumb and per layout.
- Roof bracing installed where required.
- Steel frame at all floor levels is correctly electrically earthed at one point and all earth returns are connected back to that point.
- Where galvanised steel section is cut or where any damage occurs to the steel frame a coat of zinc rich paint or galvanised spray is applied to exposed surfaces.
- All fasteners supplied or approved by Vision Built.
- No modification i.e. cutting of the steelwork is allowed without prior written permission by a Vision Built Chartered Structural Engineer.

- Always maintain a minimum 30mm between the two leaves of the party wall.
- Absorbent quilt in the cavity in the party wall has been laid horizontally with no gaps.

2.8 INFILL PANEL INSTALLATION

Structural Frame System (SFS) Infill panels can be designed for buildings in two ways:

- 1 Made to Measure: A Vision Built site manager takes actual site measurements of the existing structural frame and design panels to suit.
- 2 Designed Off Drawings: Vision Built design panels from the construction drawings with a built-in allowance for site tolerance.

The Vision Built SFS infill panel is installed on a clean structural slab which has a level tolerance of $\pm 5\text{mm}$. Vision Built approved installers install the panels.

For infill panels the bottom track of the SFS infill panel is secured to the slab with holding down bolts at the specified locations identified on the Vision Built drawings. For infill panels, brackets with a deflection allowance will allow the studs to face fix to the superstructure in question (Figure 20).

Vision Built SFS infill panels are designed to resist lateral loads only to the required deflection limit depending on the façade finish. It is critical that no permanent or variable loading from the superstructure is transferred into the infill sections. Infill panels can be designed and detailed to transfer horizontal loads, satisfactorily into the primary structure, while incorporating a soft top joint which will allow vertical deflection (See Figure 20) of the primary structure to occur but will not transfer vertical load into the LGS panel.

All vertical and horizontal fire stopping is carried out in accordance with the Vision Built Standard Erection Manual details.

2.8.1 Infill Panel Structural Design

The steel panel studs within the infill panel frame are designed to resist wind loading due to the action of wind on the building's cladding. The infill panels are not designed for vertical loads to be transferred to them. The Vision Built Infill panel can only be used within framed buildings that possess their own independent lateral stability systems and as a result a soft joint is incorporated to ensure that no load transfer occurs (Figure 20).

The design of the superstructure is to be the responsibility of the clients' structural engineer. Before carrying out this design, the clients engineer will need to liaise with Vision Built Structural Engineer, who will provide the following information:

- Load take down for Vision Built infill panel.

- The permissible deflection of the primary structure to ensure the steel frame infill panels are allowed to remain within the deflection limits set out by the design.

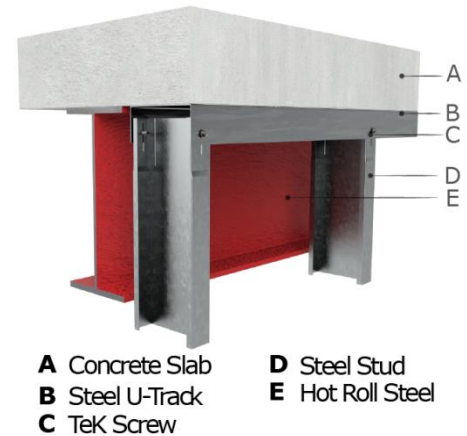

Figure 20: Deflection Head Detail for Infill Panel

3.1 STRENGTH AND STABILITY

3.1.1 Certificate of Structural Compliance

The Vision Built Steel Frame Building System is intended for use where Architect's drawings are available and satisfy the Building Regulations. The Architectural and Engineering design team of the client are responsible for the architectural drawings and overall building design to comply with the Building Regulations. Vision Built using an experienced Chartered Structural Engineer, are responsible for the structural design of the Vision Built Steel Frame Building System.

Building Control (Amendment) Regulations (S.I. 9) of 2014 (BCAR) came into action from 1st March 2014. The Vision Built system certification will typically be supplied as a sub-contractor role under BCAR projects which will require Vision Built to furnish the relevant ancillary certification per project. The appointed person within Vision Built will liaise with the Assigned Certifier (AC)/Employers Representative (ER) and the Design Certifier where applicable, furnishing the relevant Commencement Notice data, within the timeframe requested, along with an inspection notification framework summary and completion ancillary certificate as and when required.

It is imperative that all design team members are clear in relation to what elements of the project Vision Built are responsible for and what the ancillary certificate relates to.

Buildings constructed using the Vision Built Steel Frame Building System shall be certified by a competent, Chartered Engineer as being in accordance with Part A of the Building Regulations.

3.1.2 Superstructure Design

The Vision Built Building System can be designed to comply with the requirements of Part A of the Building Regulations regarding the Design to Avoid Disproportionate Collapse.

The structural assessment of the Vision Built Building System shall be site and project specific and a Structural Design Engineer suitably experienced in this type of structure shall undertake the structural engineering of every building element designed by Vision Built. In accordance with IS EN 1990:2002, *Eurocode – Basis of Structural Design*, a DSL2 (Design Supervision Level) should be employed to check the design in line with good practice.

This structural design certificate should cover the adequacy of all the cold formed and hot rolled elements within the structure in question. It should also address the dimensions and thickness of each element and member making up the steel frame superstructure, and assess the suitability of the interface between the superstructure and the external cladding. The structural certificate of compliance must also confirm that there is sufficient uplift resistance and that there is adequate racking and load bearing capacity to either side of any opening to ensure the stability of the wall. Dwellings designed and constructed in accordance with this Certificate will have adequate strength and stability as per the building codes and standards. Vision Built also undertake the structural design of every building constructed with the Steel Concrete Composite Deck and the certificate should address this also as required.

3.1.3 Substructure Design

The design of the building's substructure is outside the scope of this certificate. The design of the substructure is to be the responsibility of the Client's engineer. The Engineer will need to be a suitably qualified Chartered Engineer and the design will need to be in accordance with the relevant codes and standards, i.e. Foundation's must be designed in accordance with IS EN 1997-1:2005 *Eurocode 7 Geotechnical Design – Part 1: General Rules*. Vision Built's engineer will be responsible for undertaking a load take down for the structure and providing this information to the Client's Engineer for use in the design of the substructure. The Vision Built's Engineer will also need to provide the Client's Engineer with the permissible deflection of the ground floor slab under the Vision Built Steel Frame line loads and podium slab level loading.

3.1.4 Design Loads

The design of a typical building has been examined by the NSAI Agrément and demonstrates compliance with the following Codes of Practice. In general, the wall panels, floor trusses and roof truss are designed in accordance with:

- IS EN 1993-1-1 NA: 2007 and timber roof trusses to IS EN 1995-1-1:2004 Eurocode 5: *Design of Timber Structures Part 1-1. General - Common rules and rules for Buildings*
- IS EN 1991-1-1:2002 Eurocode 1: Actions on Structures Part 1-1: *General actions - Densities, self-weight, imposed loads for buildings*.

- IS EN 1991-1-4:2005 Eurocode 1: *Actions on Structures Part 1-4: General Actions - Wind actions.*
- IS EN 1991-1-3:2003 Eurocode 1 - *Actions on Structures Part 1-3: General Actions. Snow Loads.*

Design wind and snow loads should be based on Diagrams 1 and 14 of TGD to Part A of the Building Regulations.

Non-load bearing partitions and walls are designed in conformance with the criteria set out in BS 5234-1:1992 *Partitions (including matching linings). Code of practice for design and installation*, IS EN 10143:2006, *Continuously Hot-dip Coated Steel Sheet and Strip - Tolerances on Dimensions and Shape*. Typical design loads, in the absence of client specified, project specific loads, are:

- Imposed load on floor of 1.5kN/m² plus an allowance of 0.32kN/m² for internal partitions.
- Roof imposed loads of 0.60kN/m² with an allowance of 0.25kN/m² distributed load over a loft space with access, along with a concentrated load (point load) of 0.9kN i.e. water tank.
- Wind loads based on IS EN 1991-1-4:2005.

Greater loads can be accommodated by request.

3.1.5 Steel Concrete Composite Deck Design

Vision Built Structural Engineer is responsible for the structural design of all profiled steel composite concrete decks. The Vision Built Engineer is also responsible for design of the propping of this deck and the design of the procedure to remove the propping. A method statement for the propping of the slab must be agreed between the Clients Engineer and Vision Built's structural engineer and needs to be strictly adhered too on site.

The profiled steel deck and all accessories such as slab edge trim, restraint strap and closures etc. are installed by Vision Built trained erectors. All propping and reinforcement is done to Vision Built propping and deck reinforcement plans. The execution of the propping and reinforcement plan is the responsibility of the main contractor or Vision Built installers if included in their scope of works.

The Vision Built Structural Engineer and Vision Built Site Manager inspect the installation of all decks prior to pouring of concrete to ensure the supporting structure, including temporary props, all reinforcement, screw fixings, shutters and straps are installed correctly. The metal deck is designed to bear on to the top of the head track and must have a minimum end bearing (typically 50mm) suitable to the profile being used before it

is fixed. Steel reinforcement bars and mesh should be placed into position using concrete cover spacers, wheels and tying as required.

The concrete mix must be specified in accordance with project specific design to IS EN 1992-1-1:2005 *Eurocode 2: Design of Concrete Structures Part 1-1: General Rules and Rules for Buildings* and should be supplied and manufactured in accordance with IS EN 206:2013 and National Annex 2015 - *Concrete - Specification, Performance, Production and Conformity*. The concrete must be supplied and laid in accordance with BS EN 1992-1-1:2004+A1:2014 *Eurocode 2: Design of Concrete Structures - Part 1-1: General Rules and Rules for Buildings*. The concrete should be dispensed across the decking to avoid 'heaping' and the surface levelled in accordance with the decking manufacturer's recommendations.

The results of concrete cube compressive test must be supplied to the Vision Built Structural Engineer to ensure that the actual concrete strength attained, achieve the strengths required.

Concrete run-off and spillage should be minimised and build-up of debris in base tracks should be avoided. In cold weather, the concrete should be protected from the effects of frost and rain until adequately cured. Props are not to be removed until concrete has reached required strength, curing period and approval is given by Vision Built Structural Engineer to remove props.

3.1.6 Structural Testing

Where it is required, structural testing has been used to verify the relevant aspects of the structure where the design falls outside the scope of IS EN 1993-1-1 NA: 2007.

3.1.7 Wind Load

Buildings designed in accordance with the Vision Built Building System Design Manual will have adequate resistance to wind load in areas as outlined in Figure 1 (a) Map of wind speeds (v) in m/s of TGD to Part A of the Building Regulations). For very exposed sites on hills above the general level of the surrounding terrain, the system can be specifically designed to meet the requirements as defined in IS EN 1991-1-4:2005. The system can be designed to be used in all locations in Ireland.

3.2 STRUCTURAL FIRE SAFETY

Any dampers, ductwork, and sealing of gaps formed by services that pass through the compartment walls and floors will involve suitable tested systems which have included appropriate fire resistance testing for the required time duration. Details around penetrations and openings such as doors and windows shall avoid any excessive heat ingress into the wall cavities.

All materials such as cavity barriers and fire stops, used in the construction comply with IS EN 13501-1: 2007 *Fire Classification of Construction Products and Building Elements Part 1: Classification Using Data from Reaction to Fire Tests*. They shall be detailed as described in Section 2.5.6 (of this Certificate) and as specified in the Vision Built fire stopping details in line with the supporting documents to the Building Regulations.

Any compartment or separating wall providing fire compartmentation shall be carried up through any roof space and brought up to the underside of the roof cladding to provide adequate fire stopping. No services can pass **through a separating wall**. Services are permitted within all internal and external loadbearing and non-loadbearing walls of the Vision Built Steel Frame Building System provided the wall is not a compartment wall.

All fire testing on the Vision Built walls has been carried out with services penetrations in the wall to accurately test the system.

3.2.1 Structural Fire Safety Purpose Groups (Vol 2)

The buildings in purpose class 1(a), 1(b) & 1(d) are now covered under TGD B Fire Safety Dwelling Houses Volume 2 of the Building Regulations. Under this revision buildings designed in accordance with the Eurocodes require the structural fire resistance performance specified, to be achieved in accordance with European test methods. The European tests required to be used are IS EN 1364-1:2015 *Fire resistance tests for non-loadbearing elements, Part 1 – Wall*, IS EN 1365-1:2012 *Fire resistance tests for loadbearing elements, Part 1 – Walls*, IS EN 1365-2:2014 – *Fire resistance tests for loadbearing elements, Part 2 – Floors and roofs*.

The load-bearing and non-loadbearing elements of the above purposed classes have a fire resistance performance in accordance with the required European test method Table 4 outlines a combination of 30, 60 and 90-minute fire resistance tests.

3.2.2 Structural Fire Safety Purpose Group 2006

The other purpose classes (1(c), 2(a), 2(b), 3, 4(a) and 5) to which this certificate relates are covered under TGD B 2006 Fire Safety of the Building Regulations. Under this TGD the National Tests (BS 476) are acceptable as a means of specifying the required fire resistance performance.

Therefore, the fire resistance performances of elements of non-loadbearing and loadbearing structure are given in Table 4 as a combination of

IS EN 1364-1:2015, IS EN 1365:2-2014 and BS 476-21:1987 *Fire Tests on Building Materials and Structures – Part 21: Methods for determination of the fire resistance of loadbearing elements of construction*. Table 4 contains fire resistance tests to 30, 60 and 90 minutes.

3.3 IMPACT RESISTANCE

The interaction of components is such that, if subjected to exceptional impacts causing local failure, the overall stability of the structure will not be dangerously impaired.

4.1 BEHAVIOUR IN RELATION TO FIRE

4.1.1 Fire Resistance

Assessment of test results show that buildings constructed using the Vision Built Steel Frame Building System can meet the Building Regulation requirements in relation to fire resistance as shown in Table 4. The tests have demonstrated the ability of the Vision Built Steel Frame Building System to withstand severe fire exposure for the period required for compliance with the Building Regulations in terms of fire performance. Tests have been conducted on behalf of Vision Built to meet fire test requirements IS EN 1364-1:2015, IS EN 1365-1:2012 and BS 476-21:1987. The test required is dependent upon the purpose class of the building being designed and constructed.

The Vision Built Steel Frame Building System must be designed with the required boarding specification to meet the minimum requirements of Table A1 of TGD B 2017 Volume II of the Building Regulations for purpose class 1(a), 1(b) & 1(d), to meet the minimum requirements of Table A1 and Table A2 of TGD B 2006 of the Building Regulations for all other purpose classes to which this certificate applies, and any other building specific structural fire performance requirements. Table 4 of this Certificate provides a table of tested fire results which provide a variety of boarding specifications and their associated fire resistance performance that will have its stability maintained for the minimum required period in the event of fire.

There shall be two leaves in a steel frame separating wall with a minimum of 40mm clear cavity distance between the two leaves maintained throughout the cavity. Services shall not be placed in the cavity or penetrate the wall linings of separating walls. Where services are required, an additional service cavity shall be provided so that the integrity of the fire lining is maintained.

Services shall not be placed in the cavity of a compartment wall. Where services are required to penetrate a compartment wall, all such penetrations shall be kept to a minimum and shall be fire stopped. Where services (e.g. light switches and sockets) are placed on a compartment wall, a service cavity shall be provided so that the integrity of the fire lining is maintained. Where a compartment wall has two separate leaves, a minimum of 40mm clear distance shall be maintained throughout the wall cavity.

Accommodation of Services in Compartment Walls/Floors and Separating Walls must be in accordance with Section 3.5.4.1 of TGD B 2017 Volume 2 of Building Regulations for purpose class 1(a), 1(b) & 1(d) and in accordance with Section 3.2.5.7 and 3.4 of TGD B 2006 of the Building Regulations for all other purpose classes to which this certificate applies. Services may be surface mounted or accommodated in service ducts or within service cavities created external to the linings of the fire-resistant compartment walls or floor.

The system can be designed to accommodate sub-divided fire resisting construction in accordance with a Fire Safety Certificate where it is necessary to inhibit the spread of fire within the building.

The building details of the system incorporate suitable cavity barriers and fire stops, in accordance with IS EN 13501-1:2007, to satisfy the requirements of section 3.3 to Part B of the TGD to the Building Regulations (See Figure 6, Figure 7, Figure 13, Figure 14 and Figure 19).

An apartment, a house in a terrace and a semi-detached house are treated as separate buildings and therefore must be separated by a separating wall (party wall), as shown in Part B of the TGD to the Building Regulations as illustrated in Figure 13 and Figure 14, respectively. Where a window is required to provide an alternative means of escape in a dwelling house or apartment, it must provide an unobstructed opening of at least 0.33m² with a minimum width and height of 450mm. The opening section should be capable of remaining in the position, which provides the minimum clear area. The window should be positioned as required by BS 9991:2015 *Fire Safety in The Design, Management and Use of Residential Buildings – Code of Practice*, and BS 9999:2017, and in accordance with Part B1 of Technical Guidance Document (TGD) B of the Building Regulations. Any restrictor fitted on the window, must be easy to operate.

The fire resisting elements of the construction that are specified in Table 4 of this Certificate provide for 30, 60 and 90 minutes' fire resistance from either side, for a range of specifications.

4.1.2 Plasterboard Installation

The proper application of plasterboard to the steel frame members is critical for both fire and sound performance. Attention shall to be given to proper and practical detailing on the part of the designer

and a high standard of workmanship on behalf of the contractor. Plasterboard in addition to all cavity barriers and fire stops on all structural and separating walls must be fully checked on site and signed off by main contractor in accordance with project specific construction details. All plasterboard that provides fire resistance must conform to the requirements of Type F to IS EN 520:2005 and must be installed in accordance with the specification given in Table 4. If alternative boarding is proposed, then an independent fire test report from an Accredited Laboratory needs to be provided and assessed by a competent Fire Engineer.

4.1.3 Surface Spread of Flame

An external cladding of brick/block has a designated Class 0 surface spread of flame as shown in Table 3. For a more comprehensive list of material and product fire performance ratings, reference should be made to Table A6 of TGD to Part B of the Building Regulations. The Classes defined in accordance with BS 476-7:1997 *Fire tests on building materials and structures – Method of test to determine the classification of the surface spread of flame of products*.

Material	Fire Rating
Brickwork/Blockwork	Class 0
Timber Boarding	Class 3
Internal Plasterboard before decoration	Class 0
Slates/Tiles	AA

Table 3: Surface Spread of Flame Characteristics

4.1.4 Protection of Building

Combustible material e.g. insulation, should be separated from the flue of a masonry chimney by at least 200mm, or at least 40mm from the outer surface of the chimney. Details are given in Section 2 and diagrams 2 – 6 of TGD to Part J of the Building Regulations. The separation from a heating appliance to combustible wall insulation material should be as per Clause 2.5.6 and Diagram 6 of TGD to Part J of the Building Regulations. For chimneys, covered by IS EN 1859:2009 *Chimneys – Metal chimneys – Test methods*, separation between this product and the external surface of the chimney is determined in accordance with Clause 2.5.7 to 2.5.8 and in accordance with diagram 7 of Part J of the Building Regulations.

Combustible material in proximity to a constructional hearth must be protected by 250mm of solid concrete or as detailed in Diagram 8 of TGD to Part J of the Building Regulations.

4.1.5 Roof Designation

All tiles or slates used in the roof in conjunction with the system are designated AA in accordance with TGD to Part B of the Building Regulations

(see Table A5 notional designations of roof coverings). Other NSAI Agrément approved roof coverings may also be used with the system under the guidance of a Vision Built Chartered Engineer.

4.1.6 Cavity Barriers

The Vision Built system can incorporate both horizontal and vertical cavity barriers and fire stops to comply with the fire strategy drawings supplied by the Clients fire consultant. The main contractor is responsible for ensuring all fire stopping/cavity closers are installed in accordance with Vision Built construction drawings. The Vision Built site manager shall inspect and record all cavity closers/fire stopping at each floor level on the fire stopping check sheet supplied by Vision Built, which are kept on site for inspection. The site manager will inspect all cavity barriers and fire stops prior to the closing up of the cavities.

4.2 THERMAL INSULATION

The panels are designed as hybrid warm frame system where the LGS sections are located on the warm frame side of the insulation. Some building elements, namely the roof, ground floor, windows and doors may be site and project specific. Therefore, the U-value of these elements must be calculated before overall compliance with Part L of the Building Regulations can be determined. The Vision Built system can be provided for a wide range of required elemental u-values.

TGD Part L of the Building Regulations directs users to Digest 465 “U-values for light steel construction” published by BRE. A more precise result is obtained by using a numerical method which conforms to IS EN ISO 10211:2007.

Table 5, of this certificate, gives a range of elemental U-values for Vision Built external wall with brick outer leaf and a 50mm unventilated cavity. In addition, sample U-value for ground floor slab for a range of perimeter to area (P/A) ratios are provided in Table 8. With the appropriate amount of insulation outside of the steel frame, the system meets and exceeds the maximum back-stop elemental U-value requirements of Table 1 of TGD Part L of the Building Regulations.

4.2.1 Limiting Thermal Bridging

The linear thermal transmittance ψ -value (Psi-value) describes the heat loss associated with junctions and around openings. The certificate holder has carried out ψ -value calculations for a range of thermally bridged junctions.

Error! Reference source not found. of this certificate gives ψ -value for a range of Vision Built Steel Framed Building System junctions and their corresponding flanking elemental U-value. When flanking elemental U-values deviate by an

aggregated 20% from the target U-values given in **Error! Reference source not found.**, the ψ -values no longer remain valid and guidance must be sought from the Certificate holder. A full listing of ψ -value calculations, along with the building details on which calculations are based, are contained within the certificate holder's technical data sheets for ' Ψ ' values .

Bridged junctions where thermally modelled in accordance with BRE IP 1/06 "Assessing the effects of thermal bridging at junctions and around openings" and BRE Report BR 497 "Conventions for calculating linear thermal transmittance and temperature factors" by NSAI Certified Thermal Modellers.

The Dwelling Energy Assessment Procedure (DEAP) used to produce the Building Energy Rating (BER) for a dwelling takes account of the total effects of thermal bridging through the input of the " γ " value, with is a multiplier applied to the total exposed area of the building.

Where limited provisions are made to eliminate any risk of surface condensation or mould growth, the default " γ " value of 0.15 should be taken. When all building junctions are demonstrated to be equivalent to or better than the corresponding Acceptable Construction Details (ACD), then the " γ " value can be taken as 0.08.

Alternatively, the transmission heat loss coefficient due to thermal bridging (H_{TB}) can be calculated out by summing up the ψ -values for each junction and multiplying by the linear length of each junction. The " γ " value is calculated by dividing H_{TB} by the exposed surface area.

' Ψ ' values for other junction outside the scope of this certificate should be assessed in accordance with the BRE IP 1/06 and BRE Report BR 497 in accordance with appendix D of TGD to Part L of the Building Regulations.

4.2.2 Internal Surface condensation

As part of the assessment carried out to determine the ψ -values, internal surface temperatures factors (f_{Rsi}) are also checked. When internal surface temperature are greater than 15°C, best practice will have been adopted to safe guard against the risk of surface condensation occurring under normal occupancy and humidity class levels.

Table 9 of this certificate gives internal surface temperatures factors (f_{Rsi}) for a range of building junctions and their corresponding flanking elemental U-value.

The Vision Built Steel Frame Building System has been assessed and when detailed in accordance with this certificate, these thermally bridged

junctions comply with the requirements of Section D.2 of appendix D of TGD to Part L of the Building Regulations.

4.3 VENTILATION

4.3.1 Un-designed Air Infiltration

Air permeability can be measured by means of a pressure test and this is now a mandatory requirement under TGD to Part L of the Building Regulations to show compliance with the backstop air permeability index of 7 m³/(hr.m²) at a pressure differential of 50Pa across the building envelope.

When inputting values into DEAP, the measured air permeability index at a pressure differential of 50Pa across the building envelope is divided by 20 to determine an air permeability value which is more representative of the actual pressure differential across the building envelope under normal conditions.

The procedure for testing is specified in I.S. EN ISO 9972:2015 - *Thermal Performance of Buildings – Determination of Air Permeability of Buildings – Fan Pressurization Method*.

On each development, an air pressure test should be carried out on at least one unit of each dwelling type. The basic or minimum number of air pressure tests for each dwelling type is described in Table 4 of TGD to Part L of the Building Regulations. When using this method to demonstrate compliance for a multi-unit development, then the backstop air permeability index of 7 m³/(hr.m²) must be entered in DEAP for all untested units.

When using air permeability values better than the backstop values of 7 m³/(hr.m²), a test must be performed on each unit.

When air permeability values better than 5 m³/(hr.m²) are achieved, the guidance given in Clause 4.3.2 of this certificate should be considered.

The Vision Built Steel Frame Building System can be designed to provide the required project specific airtightness requirement and can be achieved in practice due to its offsite production process, hybrid construction build up and the quality of product produced in a factory-controlled environment. The Vision Built Steel Frame Building System will therefore significantly contribute to the reduction of air permeability from a building. To enhance the airtightness performance an AVCL can be installed on all external walls and ceiling lines but this must be done at design stage to maximize performance as part of airtightness strategy and reduce penetrations of the airtightness line for the building. To avoid excessive heat losses due to

un-designed air infiltration, it is necessary to install peripheral seals around windows, doors, services, floors, roof and all building junctions which penetrate the envelop of the building component relied upon to perform the air sealing function of the building.

4.3.2 Designed Ventilation

TGD to Part F of the Building Regulations prescribes ventilation requirements to meet needs of occupants within the building. This can be achieved by limiting moisture content of the air within the building so that it does not contribute to condensation and mould growth and to limit the concentration of harmful pollutants in the air within the dwelling.

In addition to ventilation requirements within the dwelling living space, TGD to Part F makes provisions for ventilation requirements in roofs and roof voids above the insulation line. These provisions will allow for the removal of moisture laden air or condensation which may enter the roof structure from the dwelling either through diffusion or exfiltration.

When air permeability values better than 5 m³/(hr.m²) are achieved, the basic provisions for background ventilators shall be increased as described in Clause 1.2.2.1 of TGD to Part F of the Building Regulations.

When continuous mechanical ventilation systems are being considered, low air permeability values will be required for the energy efficient operation of the mechanical systems.

4.4 INTERSTITIAL CONDENSATION

4.4.1 Condensation in Walls

Calculations to BS 5250:2011+A1:2016 have been carried out for all possible wall build ups as covered by this certificate and predict no interstitial condensation within the external wall and pass the risk criteria in IS EN ISO 13788:2012 *Hygrothermal performance of building components and building elements and building elements – Internal surface temperature to avoid critical surface humidity and interstitial condensation – Calculation Methods*.

It is recommended to provide an AVCL behind the plasterboard to protection against interstitial condensation. This can be either in the form of a foil backed plasterboard or a continuous AVCL membrane with joints sealed. In situations where

a AVCL is omitted, a condensation risk calculation must be provided by the Certificate holder to assess the build-up proposed, considering the location of the building, the buildings occupancy and purpose class.

4.4.2 Condensation in Roof

In both cold (insulation at ceiling level) and warm (insulation along the slope) roofs, it is recommended that an AVCL is provided on the warm side of the insulation to limit the migration of moisture laden air from the dwelling, entering the roof structure through diffusion. The AVCL can double as the air tight barrier.

Roof ventilation should be carried out in accordance with TGD Part F of the Building Regulations and the recommendations of BS 5250:2011+A1:2016. It is important to ensure that the ventilation is not obstructed by roof insulation at eaves level. When roof insulation is packet into the eaves space, proprietary eaves tray may be provided to maintain ventilation at the eaves.

In the case of cold flat roofs, a cross-ventilated void, not less than 50mm deep, between the slab or deck and insulation should be provided in conjunction with the AVCL being provided on the warm side of the insulation. Ventilation openings should be provided to every roof void along two opposite sides of the roof and should be equivalent in area to a continuous opening of not less than 25mm at each side. It should also be noted that the dimensions of the cross-ventilated void and the ventilation depends on the size of the roof.

In the case of warm flat roofs, the risk of surface condensation is dependent on the nature of the supporting structure. With all flat roofs, there is a risk of interstitial condensation forming between the thermal insulation and the waterproof covering. To avoid this risk, an AVCL should be provided immediately above the supporting structure.

In the case of inverted flat roofs, it is essential that the thermal insulation used resists water absorption and is sufficiently load bearing to support the protective finish of ballast, paving or soil.

Table 4: Fire Protection Requirements for Loadbearing Wall, Floor and Ceiling Elements

Type	Element:	Test Standard	Results	Purpose Class
External & Internal Load Bearing Walls				
1	External Load Bearing Partition Wall up to 10kN per Stud Steel C-Studs (65 to 150mm deep) with a single layer 12.5mm Firecheck board fixed to the face exposed to the fire and 48.5mm thermal sheeting to non-fire side with 60mm mineral wool insulation between studs	IS EN 1365-1:1999	30 mins from exposed side	1(a), 1(b), 1(c), 1(d), 2(a), 2(b), 3, 4(a) and 5
2	External Load Bearing Partition Wall up to 10kN per Stud Steel C-Studs (103mm deep) with a double layer 12.5mm Firecheck board fixed to the face exposed to the fire and 50mm Kingspan Thermapitch to non-fire side with 50mm mineral wool between studs.	IS EN 1365-1:1999	60 mins from exposed side	1(a), 1(b), 1(c), 1(d), 2(a), 2(b), 3, 4(a) and 5
3	External Load Bearing Partition Wall up to 10kN per Stud Steel C-Studs (90 x36x1.2mm) with a single layer 15mm Megadeco board fixed with self-drilling screws to studs. Stud filled with 50mm Rockwool 45kg/m ³ density. Unexposed face clad with 12.5mm GTEC Weather Defence.	BS 476-21:1987	60 mins from exposed side	1(c), 2(a), 2(b), 3, 4(a) and 5
4	Load Bearing Partition Wall up to 10kN per Stud Steel C-Studs (65 to 150mm deep) with a single layer 12.5mm Firecheck board fixed to both faces with 25mm mineral wool between studs.	IS EN 1365-1:1999	30 mins from either side	1(a), 1(b), 1(c), 1(d), 2(a), 2(b), 3, 4(a) and 5
5	Load Bearing Partition Wall up to 10KN per stud Steel C Stud 100 x 44 x 1.2mm with a single layer ⁽²⁾ of 15mm Type F plasterboard. (GTEC Fire Board). Note loadbearing performance is affected by horizontal joints therefore horizontal joints require a steel backing strip or full height board may be used. Alternative two layers of 12.5 Type F board can be used.	BS 476-21:1987	60 mins from either side	1(c), 2(a), 2(b), 3, 4(a) and 5
6	Load Bearing Partition Wall up to 10KN per stud Steel C Stud 100 x 44 x 1.2mm with two layers ⁽²⁾ of 15mm Type F plasterboard. (GTEC Fire Board). 75mm Rockwool Flexi Batt at 33kg/m ³ between studs. All boards staggered	BS 476-21:1987	90 mins from either side	1(c), 2(a), 2(b), 3, 4(a) and 5
Separating Walls				
7	Load Bearing Partition Wall up to 10kN per Stud Steel C-Studs (100 to 150mm deep) with a 15mm sound resistant board and 15mm Megadeco fixed to both faces with 50mm mineral wool between studs. ⁽¹⁾	IS EN 1365-1:1999	60 mins from either side	1(a), 1(b), 1(c), 1(d), 2(a), 2(b), 3, 4(a) and 5
8	Load Bearing Partition Wall up to 13kN per Stud Double Steel C-Studs (75mm deep) separated by 50mm gap and connected using steel V-ACB brackets with a 15mm standard wallboard and 15mm Firecheck board fixed to both faces with 50mm mineral wool between studs. ⁽¹⁾	IS EN 1365-1:1999	60 mins from either side	1(a), 1(b), 1(c), 1(d), 2(a), 2(b), 3, 4(a) and 5
Non-Load Bearing Walls				
9	Steel C-Studs (90mm deep) with single layer of 15mm Type F plasterboard fixed to both faces with no glass wool between studs.	IS EN 1364-1:1999	60 mins from either side	1(a), 1(b), 1(c), 1(d), 2(a), 2(b), 3, 4(a) and 5

10	Steel C-Studs (90mm deep) double layer of 12.5mm thick Firecheck board fixed to both faces. 25mm 16kg/m ³ glass mineral wool between studs.	IS EN 1364-1:1999	120 mins from either side	1(a), 1(b), 1(c), 1(d), 2(a), 2(b), 3, 4(a) and 5
Compartment floors: Loaded Floors Joist or Truss				
11	Floor supporting an imposed load of 1.5kN/m² with ceiling protection Steel lattice beam joists (228mm deep x 65mm wide) with 50mm mineral insulation between joists, 19mm T&G chipboard screwed to top of joists, protected on the underside with single layer of 12.5mm Firecheck board.	IS EN 1365-2:2000	30 mins from below ceiling level	1(a), 1(b), 1(c), 1(d), 2(a), 2(b), 3, 4(a) and 5
12	Steel C joists (200mm deep x 63mm wide x 1.6mm thick) with joists at 600mm intervals. Resilient bar was fixed to underside of joist at 400mm centres running perpendicular to joists. One layer of 12.5mm Type F fire resistant plasterboard fixed to underside of resilient bars. A layer of 100mm mineral insulation fitted between joists. 22mm T&G chipboard screwed to top of joists.	IS EN 1365-2:2000	30 mins from below ceiling level	1(a), 1(b), 1(c), 1(d), 2(a), 2(b), 3, 4(a) and 5
13	Steel C joists (200mm deep x 63mm wide x 1.6mm thick) with joists at 600mm intervals. Resilient bar was fixed to underside of joist at 400mm centres running perpendicular to joists. Two layers of 15mm Type F fire resistant plasterboard fixed to underside of resilient bars. A layer of 100mm mineral insulation fitted between joists. 22mm T&G chipboard screwed to top of joists.	IS EN 1365-2:2000	60 mins from below ceiling level	1(a), 1(b), 1(c), 1(d), 2(a), 2(b), 3, 4(a) and 5
14	Floor supporting an imposed load of 250kg/m² with ceiling protection Steel C joists (200mm deep x 63mm wide x 1.6mm thick) with joists at 400mm intervals. Resilient bar was fixed to underside of joist, running perpendicular to joists. Three layers of 12.5mm Type F fire resistant plasterboard fixed to underside of resilient bars. All joints in boards were staggered. A layer of 100mm mineral insulation fitted between joists. 18mm T&G chipboard screwed to top of joists.	IS EN 1365-2:2000	90 mins from below ceiling level	1(a), 1(b), 1(c), 1(d), 2(a), 2(b), 3, 4(a) and 5
Compartment floors: Loaded Floors Composite Metal Deck				
15	Loaded Floor supporting uniformly distributed load of 6.7kg/m². 140mm normal weight concrete on 0.9mm Multideck 60. Concrete reinforced with A 142 mesh with a minimum 25mm cover below the upper surface.	BS 476-21:1987	60 mins from below deck	1(c), 2(a), 2(b), 3, 4(a) and 5
16	Loaded Floor supporting uniformly distributed load of 6.7kg/m². 150mm normal weight concrete on 1.2mm Multideck 80. Concrete reinforced with A252 mesh with a minimum 25mm cover below the upper surface.	BS 476-21:1987	90 mins from below deck	1(c), 2(a), 2(b), 3, 4(a) and 5
Notes:				
<p>(1) Please note a minimum of 2 x15 mm boards are required for separating walls from each room side. Where services are placed on a separating wall, a cavity shall be provided so that the integrity of fire lining is maintained.</p> <p>(2) For load-bearing walls the load ratio should be less than 0.4. For higher load ratio 3 layers of 12.5mm boards may be required.</p> <ul style="list-style-type: none"> It is assumed that the composite decks are adequately supported by a suitable fire-resisting structure. Supporting structure must be fully protected to underside of composite deck including any concealed cavities. For load/span conditions deck manufactures guidance must be strictly followed. Residential (Dwellings) Group 1(a)⁽¹⁾⁽²⁾, 1(b)⁽¹⁾⁽²⁾, 1(d)⁽¹⁾ All fire testing must be to relevant EN standard to meet requirements of TGD B 2017 Fire Safety Dwelling Houses Volume 2. 				

External walls U-value for variable PIR thickness		
<p>Wall build-up:</p> <p>Layer 1: Brick/masonry cladding</p> <p>Layer 2: 50mm low E cavity</p> <p>Layer 3: Variable PIR layer ⁽²⁾⁽³⁾ (see below)</p> <p>Layer 4: LGS/PUR insulation ⁽¹⁾</p> <p>Layer 5: LGS/MW insulation ⁽¹⁾</p> <p>Layer 6: 15mm Plasterboard on AVCL</p>		
Wall thickness	PIR variable thickness:	Calculated U-value (W/m ² K)
320mm	60mm	0.21
330mm	70mm	0.19
340mm	80mm	0.18
350mm	90mm	0.17
360mm	100mm	0.16
370mm	110mm	0.15
380mm	120mm	0.14
390mm	130mm	0.13
<p>Calculation comply with BRE Digest 465 U-values for light steel-frame construction</p> <p>⁽¹⁾ Corrections have been made for 1.5mm LGS studs @ 600mm c/c bridging layer 4 & 5.</p> <p>⁽²⁾ A level 1 correction for air voids has been applied to layer 3, 4 & 5 (IS EN ISO 6946 Table D.1)</p> <p>⁽³⁾ Correction for mechanical fasteners have been applied to layer 5 equating to 6 No. 5.4mm Ø Stainless steel fixing per m² to connect brick tie channel to LGS section.</p>		

Table 5: Typical External Wall U-Values

Sample U-value Calculation for 80mm PIR					
Layer	Description	% Bridged	Thickness [mm]	Thermal conductivity λ [W/m K]	Thermal resistance R [W/m ² K]
	Rse				0.040
1	Brickwork		102.5	0.77	0.133
2	Cavity Low-e (0.9, 0.06)		50	0.078	0.644
3	PIR Insulation		80	0.023	3.478
4	PUR Spray Foam	0.9975	4.2	0.029	0.145
	Steel Stud	0.0025	4.2	50	0.0001
5	Mineral Wool	0.9975	84.8	0.040	2.120
	Steel Stud	0.0025	84.8	50	0.0017
6	Firecheck Plasterboard		15	0.25	0.060
	Rsi				0.130
Ru Total =					6.741
RL Total =					5.026
From BRE Digest 465 P = 0.681, R _T = pR _{max} + (1 - p)R _{min} =					6.194
Correction term, ΔU =					0.01596
Corrected U-Value (2DP) =					0.18 W/m ² K
Correction as described in Table 5 apply					

Table 6: Sample U-value calculation for 80mm PIR

Effect on 0.18 W/m ² K (80mm PIR) U-value for variations in LGS thickness and centres						
Centres of studs	LGS Thickness (Gauge)					
	0.8m	1.0mm	1.2mm	1.5mm	2.0mm	2.5mm
300mm	0.19	0.19	0.19	0.20	0.20	0.20
400mm	0.18	0.18	0.18	0.19	0.19	0.19
600mm	0.17	0.17	0.18	0.18	0.18	0.18

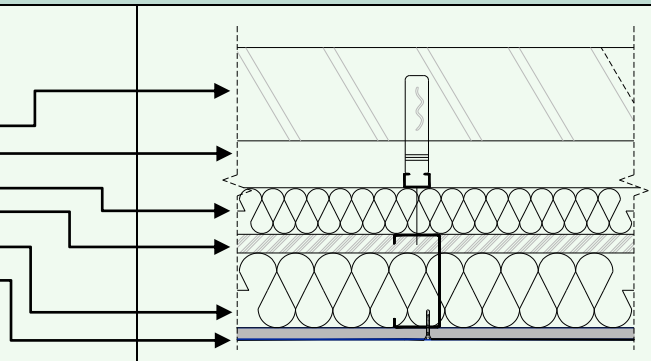
Table 7: Effect on U-value for variations in LGS thickness and centres

Ground Floor slab U-value for varying P/A ratio											
P/A Ratio	0.10	0.15	0.20	0.25	0.30	0.35	0.40	0.45	0.50	0.55	0.60
U-value	0.086	0.097	0.105	0.11	0.114	0.116	0.119	0.12	0.122	0.123	0.124

Floor U-values based on 150mm RC Slab on 150mm PIR insulation ($\lambda=0.022$) on soil ($\lambda=2.0$).
P/A Ratio = Exposed perimeter of the floor to total ground-floor area ratio.

Table 8: Typical Ground Floor U-Values

Target linear thermal transmittance (ψ) for different types of junctions.			
ACD Ref:	Junction Description	Temperature Factor f_{Rsi} (Min = 0.75)	Ψ -value (W/m.K)
5.02	Ground Floor - Insulation below slab ⁽²⁾	0.757	0.21
5.03	Intermediate Floor	0.953	0.01
5.04	Separating Wall edge (plan) ⁽¹⁾⁽²⁾	0.890	0.05
5.05	Separating Wall top (section) ⁽¹⁾	0.890	0.056
5.07/5.08	Eaves Detail, plastic isolation plates, PIR between farrat plates over wall plate ⁽²⁾	0.800	0.108
5.15	Gable end detail ⁽²⁾	0.810	0.088
5.19	Ope - Lintel - Mineral wool Cavity Closer ⁽²⁾	0.750	0.04
5.20	Ope - Jamb - Mineral wool Cavity Closer ⁽²⁾	0.929	0.026
5.21	Ope - Sill - pressed metal sill, Prop. Cavity Closer ⁽²⁾	0.859	0.132
5.22.1	Steel Frame Separating Wall through ground floor (base) ⁽¹⁾	0.880	0.069
5.23.1	Corner Detail ⁽²⁾	0.860	0.056
5.23.2	Inverted Corner Detail	0.960	-0.043

⁽¹⁾ Value of ψ is applied to each dwelling.
⁽²⁾ Some ψ -values do not meet the default ψ -values, however all junctions pass f_{Rsi} assessments.
⁽³⁾ Flanking element U-values for walls, roof and floor thermal models above were based on, $U_W = 0.15$ W/m²k, $U_F = 0.11$ W/m²k, $U_R = 0.082$ W/m²k

Table 9: Typical ψ -Value W/mK

4.5 SOUND

4.5.1 Party Wall

The acoustic performance of the party wall specified in Section 2.5.1 has been assessed by both on site testing and comparison with Robust Standard Details for Separating Wall - E-WS-1 and *SCI Publication P 372 Acoustic Detailing for Steel Construction* (Separating wall twin light steel frames) and through adopting best practice at salient junctions to minimise the effects of airborne, impact and flanking sound. In respect of party walls (separating wall) an examination was also carried out of the key junctions in the external walls to ensure compliance with the

requirements of Part E of the Building Regulations.

The specification for the separating wall achieves airborne sound insulation through the following:

- Structural isolation is achieved by leaving a minimum 30mm cavity between the two steel frames.
- This cavity is then full filled with stone mineral wool of minimum 24kg/m³ density. These wool batts are continuous from ground floor to the upper floor ceiling level and provide the required acoustic properties.
- Mass is achieved using dense wall linings. Each steel frame is boarded with two layers of

15mm sound check or Fire grade plasterboard which provided the minimum 60 minutes' fire resistance required. All Joints between the outer layer of plasterboard layer are staggered, taped and filled in accordance with manufacturers specifications.

- Prevention of flanking sound by sealing between the end of the separating wall frames and the outer masonry leaf as shown in Figure 13 and Figure 14.
- At the junction of the compartment floor and the party wall, an additional 500mm section of mineral wool fibre insulation is provided within the cold formed section zone each side of the 70mm stone mineral wool layer to minimise flanking and direct sound transmission.

The separating wall (party wall) in the Vision Built Steel Frame Building System has been assessed and when constructed in accordance with this certificate can meet the requirements of TGD to Part E of the Building Regulations.

4.5.2 Compartment Floor Truss

The acoustic performance of the compartment floor specified in Section 2.5.3.1 has been assessed by both on site testing and comparison with Robust Standard Details for Separating Floor-Metal Joist E-FS-3 and SCI Publication P 372 Acoustic Detailing for Steel Construction (Separating floor Light steel lattice truss with acoustic boarding). Best practice has been adopted at salient junctions to minimise the effects of airborne, impact and flanking sound. In respect of compartment floor (separating floor) an examination was also carried out of the key junctions with the external walls to ensure compliance with the requirements of Part E of the Building Regulations (See Figure 15).

4.5.3 Compartment Floor Steel Concrete Composite Deck

The composite deck can meet either the requirement of a **Type 1** (Figure 17) floor concrete base with a soft covering or a **Type 2** (Figure 18) floor concrete base with a floating floor as described in section 4 of TGD to Part E of the Building Regulations.

In both floor types, the resistance to airborne sound depends mainly on the mass of the concrete base, plasterboard ceilings and good flanking detailing. In Type 1 the soft covering reduces the impact sound at source. The mass per unit area of the floor, coverings and ceilings meet the specification for a Type 1 separating floor. The impact sound reduction is achieved with the use of a 5mm layer of soft floor covering. This covering is not intended to be the final finished floor but is intended to act as resilient layer beneath different floor finishes such as vinyl, carpet, timber flooring, tiles etc.

In the Type 2 floor with a concrete base and a floating layer, the floating layer reduces the transmission of impact sound to the base and to the surrounding construction.

4.5.4 Lightweight Floating Floors on Compartment Floors

A lightweight floating floor consists of a floating layer and resilient layer. A floating floor uses a resilient layer to isolate the walking surface from the base and this isolation contributes to both airborne and impact sound insulation. There are two principal floating floor systems that have been assessed. The joist and steel concrete composite deck compartment floor systems have been assessed with both an approved batten system and an acoustic flooring grade Rockwool product.

4.5.5 On Site Testing

Sound insulation testing is now a mandatory requirement to comply with TGD to Part E of the Building Regulations. All flooring systems have been acoustically field-tested and meet the requirements set out in TGD to Part E.

Sound insulation testing was carried out in accordance with IS EN ISO 16283-1:2014 Acoustics - Field Measurement of Sound Insulation in Buildings and of Building Elements Part 1: Airborne Sound Insulation and IS EN ISO 16283-2:2015 Acoustics - Field Measurement of Sound Insulation in Buildings and of Building Elements Part 2: Impact Sound Insulation.

Vision Built Steel Frame Building System separating wall and floor details have been assessed and when constructed in accordance with this certificate, can meet the minimum sound level performance outlined in TGD to Part E of the Building Regulations.

4.6 ACCESS FOR PEOPLE WITH DISABILITIES

4.6.1 Access and Use

Building designs can accommodate minimum dimensions for doors/corridors/rooms and circulation spaces to provide access for people with disabilities as indicated in Diagrams 5 - 12 of TGD to Part M of the Building Regulations.

4.6.2 Sanitary Conveniences

Buildings can be designed to meet the installation requirements for all necessary and special sanitary conveniences for people with disabilities.

4.7 WEATHERTIGHTNESS AND DAMP PROOFING

Suitable precautions must be undertaken when preparing the site for the installation of the system so that water cannot flow or pond under the substructure. Unless a peripheral drainage system is to be used, the finished ground level adjacent to the building must be maintained at a minimum of 150mm below the DPC, which must not be bridged.

Thresholds shall be detailed to allow level access (as required), while protecting the steel frame from weather and ground moisture. Weep holes and cavity vents should be avoided in immediate threshold areas and should be placed on either side of the threshold.

4.7.1 Floor Damp Proofing

The system has adequate DPCs and DPMs to resist the passage of moisture from the ground.

4.7.2 Roof Cladding

Roof coverings will provide adequate weather resistance in all situations covered by Section 3 of this Certificate, when completed in accordance with this Certificate and the manufacturer's instructions.

4.7.3 External Cladding

The external wall with masonry/brick outer leaf incorporates a 50mm clear cavity, when correctly constructed with well filled perpend and mortar-free cavity ties, will minimise the risk of water reaching the cavity face of the inner leaf. For other NSAI Agrément approved wall cladding systems in exposed areas, a water barrier is fixed behind the 25mm (clean) cavity between inner leaf and external cladding, and this minimises the risk of water reaching the inner leaf. Joints, in the insulating lining to the inner leaf, are weatherproofed and any penetrations are sealed. Wind-driven rain, which may cross the cavity under adverse conditions, will be effectively prevented from penetrating the inner leaf.

The construction of the external panels also keeps the galvanised steel frame members in a "warmframe" environment, which prolongs the life of the steel. Stepped DPC must be provided over window and door heads to deflect moisture that enter the cavity from entering the dwelling/building. Good building practice such as stepped DPC (Figure 22) and weep-holes are essential to ensure that moisture within a cavity is deflected to the outside of the building.

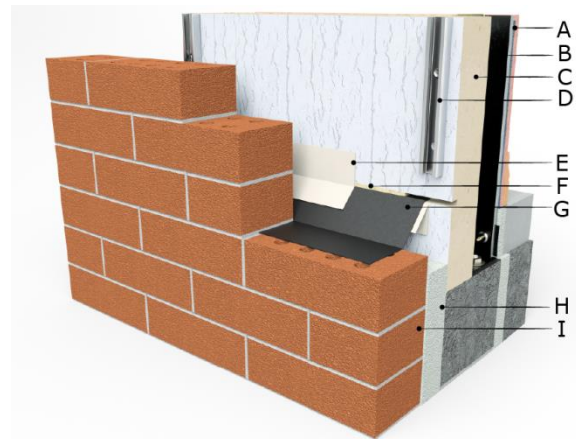

- | | |
|---------------------------------------|--------------------------------|
| A Plasterboard | F PU Foam |
| B Steel Stud | G DPC |
| C P.I.R./Phenolic Insulation | H Styrofoam |
| D Stainless Steel Wall Channel | I External Masonry Wall |
| E Tape | |

Figure 21: Stepped DPC Detail preventing ingress of moisture from outer inner leaf of Construction

4.7.4 Windows and Doors

This Certificate does not cover the installation or performance of windows and doors. However, the detailing at window and door openings has been assessed and is considered adequate to ensure that water penetration will not occur at these locations assuming conventional window frame profiles and sealing arrangements are used. Figure 2 and Figure 22 show typical details that can be used with the system.

Window sills and external thresholds must either be impervious, run the full width of the cavity and be suitably jointed to a horizontal, continuous cavity tray or DPC which is preferably flexible or a cavity tray must be provided under the opening provision. Good attention to detail must be given to ensuring that, when installing the horizontal cavity tray or DPC below an external window board, provision for any condensation that may occur on the window is deflected into the cavity and away from the steelwork. The windows and doors are made to order by the window manufacturer using the dimensions provided by the Vision Built design office.

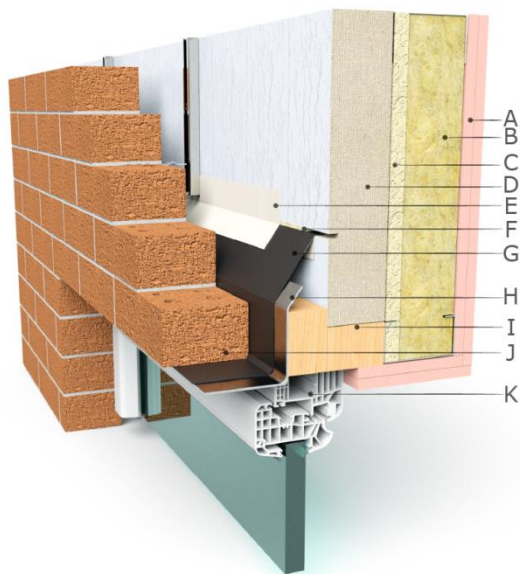

A Plasterboard	G DPC
B Rockwool	H Steel Lintel
C Closed Cell Insulation	I Timber Batten
D P.I.R./Phenolic Insulation	J External Masonry Wall
E Tape	K Window
F PU Foam	

Figure 22: Window Head Detail Showing DPC

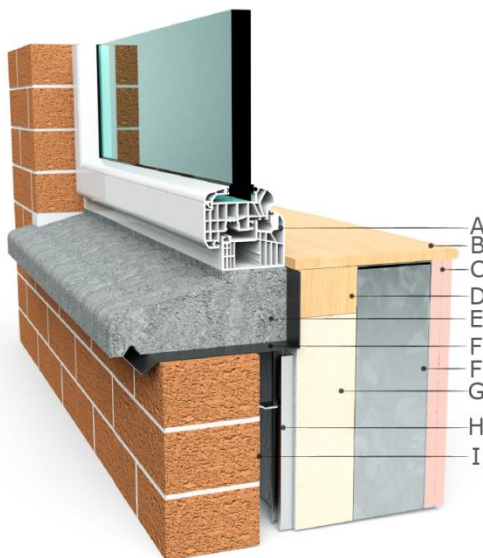

A Window	F Steel Stud
B Timber Cillboard	G P.I.R./Phenolic Insulation
C Plasterboard	H Stainless Steel Wall Channel
D Timber Batten	I External Masonry Wall
E Cement Cill	

Figure 23: Window Sill Detail showing DPC

4.7.5 Rain Water Goods

Buildings constructed using the Vision Built Steel Frame Building System can readily accommodate adequate rainwater gutters and down pipes.

4.8 ELECTRICAL AND PLUMBING SERVICES

Electrical and plumbing services are outside the scope of this Certificate. However, in designing and installing these services it is essential that the following procedures are followed and precautions are taken to minimise the risk of long-term damage to the steel frame or the services.

- At the design stage, it is useful if the positions and sizes of services can be established in advance, as special holes may be cut in the factory to help with the rapid and economic installation of services. A considerable amount of services is generally required in bathroom, hot press and utility areas.
- In general, the steel frame at each floor level must be connected directly onto the main earthing terminal in the main fuse box and all earth connections in the circuit wired back to this point. This measure is necessary to control the flow of electric current to earth without the risk of corrosion of critical structural components. However, the earthing system must be installed in accordance with the National Rules of the Electro Technical Council of Ireland E.T. 101 (current version).
- All unswaged service holes in the steel frame members must be fitted with rubber or plastic grommets to avoid damage to services. To ease the installation of services, particularly electrical cables, these purpose-made rubber or polyethylene grommets form the inner face of the openings. The service holes may alternatively be formed by swaging which is fully rounded to offer a non-sharpened surface to the services. Where plastic coated electrical wiring is in contact with insulation, then the cables must be enclosed in a suitable conduit, e.g. PVC as outlined in the National Rules of the Electro Technical Council of Ireland E.T. 101 (current version).
- Under no circumstances should electrical cables be placed within compartment floors, walls and/or party walls. Walls must be battened out to provide a false service zone in which to distribute electrical services on these fire rated build-ups.
- The enclosure of cold water pipe work within the external wall should be avoided as condensation on the pipe work could lead to wetting of the steel frame with a consequent risk of corrosion. If enclosure is unavoidable, the cold-water pipework must be insulated with tubular plastic insulation, which must be accurately cut at junctions and at changes of direction and held firmly in place with adhesive tape. Where hot water pipework is enclosed in the inner leaf of the wall, contact between copper pipes and the galvanised frame must be avoided using rubber or plastic grommets.

- Additional slots, notches or holes should not be cut through any steel member without the approval of the Chartered Structural Engineer responsible for the overall design of the structure.

4.9 DURABILITY

The steel frame structure and wall cladding has been assessed as capable of achieving a minimum design life of 60 years. The steel structure is constructed from steel members having a minimum 275g/m² Zinc galvanised coating which will provide adequate protection to the steel members. In addition to this, the steel is kept in a "warmframe" environment, which should prolong the life of the steel. The DPC and the galvanising will provide adequate protection to ensure that the bottom channel has a life equal to that of the other frame members.

The rigid PIR and mineral wool insulations are durable materials and will remain effective as an insulant for the life of the building. The roof, internal wall and ceiling linings and the outer leaf of the external wall are all constructed from conventional durable materials.

Buildings constructed using the Vision Built Steel Frame Building System will, when constructed in accordance with Vision Built Erection Manual and the requirements of this Certificate along with all relevant codes of practice will have a minimum design life of at least 60 years in accordance with BS 7543:2015 *Guide to durability of buildings and building elements, products and components*.

4.10 MAINTENANCE

Maintenance will be required at a level comparable with that for buildings of traditional construction. The elimination of wet trades in the construction of the inner leaf of external walls reduces drying time and can reduce the incidence of superficial cracking early in the life of the building.

As the plasterboard is screwed into the steel structure, there is no nail popping in plasterwork, which results in less maintenance of plasterwork, than that of a traditionally constructed building.

Repainting should be carried out in accordance with the relevant recommendations of BS 6150:2006+A1:2014 *Painting of buildings. Code of Practice*. Timber boarding, fascia's, soffits etc. where used, should be treated with an appropriate paint system or translucent stain and should be maintained by periodic re-coating using a paint or stain suitable for external applications, applied in accordance with the manufacturer's instructions.

The joints in windows and doors may require resealing at approximately 10 year intervals.

4.11 TESTS AND ASSESSMENTS WERE CARRIED OUT TO DETERMINE THE FOLLOWING

The following is a summary of the tests and assessments which have been carried out on the Vision Built Steel Frame Building System:

- Structural strength and stability (racking resistance, load bearing capacity).
- Behaviour in relation to fire.
- Acoustic performance, resistance to airborne and impact sound transmission.
- Thermal insulation performance.
- Corrosion of fasteners in normal conditions with a view to a minimum 60-year design life.
- Compatibility with other materials.
- Risk of condensation both surface and interstitial.
- Pre-completion airtightness testing.
- 3D thermal modelling of junction details in accordance with BRE IPI/06
- The Vision Built Building System Erection Manual

4.11.1 Other Investigations

Existing data was examined to assess:

- Adequacy of weather tightness of building constructed using the system.
- Durability of the system.
- Requirements for maintenance.

4.11.2 Production Audits

Production audits were carried out at the Vision Built factory to examine the process of structural design, steel frame fabrication, assembly and to assess the adequacy of the methods adopted for quality control.

4.11.3 Site Erection Visits

Buildings under construction were visited to assess the practicability of construction (erection) and the adequacy of Vision Built site supervision arrangements.

5.1 National Standards Authority of Ireland ("NSAI") following consultation with NSAI Agrément has assessed the performance and method of installation of the product/process and the quality of the materials used in its manufacture and certifies the product/process to be fit for the use for which it is certified provided that it is manufactured, installed, used and maintained in accordance with the descriptions and specifications set out in this Certificate and in accordance with the manufacturer's instructions and usual trade practice. This Certificate shall remain valid for five years from date of issue or revision date so long as:

- (a) the specification of the product is unchanged.
- (b) the Building Regulations and any other regulation or standard applicable to the product/process, its use or installation remains unchanged.
- (c) the product continues to be assessed for the quality of its manufacture and marking by NSAI.
- (d) no new information becomes available which in the opinion of the NSAI, would preclude the granting of the Certificate.
- (e) the product or process continues to be manufactured, installed, used and maintained in accordance with the description, specifications and safety recommendations set out in this certificate.
- (f) the registration and/or surveillance fees due to NSAI Agrément are paid.

5.2 The NSAI Agrément mark and certification number may only be used on or in relation to product/processes in respect of which a valid Certificate exists. If the Certificate becomes invalid the Certificate holder must not use the NSAI Agrément mark and certification number and must remove them from the products already marked.

5.3 In granting Certification, the NSAI makes no representation as to;

- (a) the absence or presence of patent rights subsisting in the product/process; or
- (b) the legal right of the Certificate holder to market, install or maintain the product/process; or
- (c) whether individual products have been manufactured or installed by the Certificate holder in accordance with the descriptions and specifications set out in this Certificate.

5.4 This Certificate does not comprise installation instructions and does not replace the manufacturer's directions or any professional or trade advice relating to use and installation which may be appropriate.

5.5 Any recommendations contained in this Certificate relating to the safe use of the certified product/process are preconditions to the validity of the Certificate. However, the NSAI does not certify that the manufacture or installation of the certified product or process in accordance with the descriptions and specifications set out in this Certificate will satisfy the requirements of the Safety, Health and Welfare at Work Act 2005, or of any other current or future common law duty of care owed by the manufacturer or by the Certificate holder.

5.6 The NSAI is not responsible to any person or body for loss or damage including personal injury arising as a direct or indirect result of the use of this product or process.

5.7 Where reference is made in this Certificate to any Act of the Oireachtas, Regulation made thereunder, Statutory Instrument, Code of Practice, National Standards, manufacturer's instructions, or similar publication, it shall be construed as reference to such publication in the form in which it is in force at the date of this Certification.

NSAI Agrément

This Certificate No. **17/0391** is accordingly granted by the NSAI to **Vision Built Manufacturing Ltd.** on behalf of NSAI Agrément.

Date of Issue: **June 2017**

Signed



Kevin D. Mullaney
Director of NSAI Agrément

Readers may check that the status of this Certificate has not changed by contacting NSAI Agrément, NSAI, 1 Swift Square, Northwood, Santry, Dublin 9, Ireland. Telephone: (01) 807 3800. Fax: (01) 807 3842. www.nsai.ie

Revisions:

- **07th November 2023:** References to Building Regulations updated.