



NSAI

NSAI Irish Standard
certification mark;
usage guidelines

CONTENTS

Introduction

NSAI Irish Standard mark

Application guidelines

Incorrect usage examples

Thank-you

INTRODUCTION

NSAI's Irish Standard certification mark represents the most respected level of certification available in Ireland today.

Bearers of this mark have achieved and maintained the required standard as defined by NSAI. It is essential that the mark is displayed in a clear and consistent way.

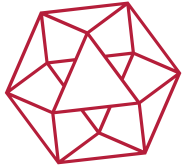

NSAI

NSAI brand identity

NSAI's brand identity represents all the varied functions and is the corporate signature when NSAI communicates with industry and the general public.



Irish Standard symbol

NSAI awards the Irish Standard symbol to products & services that have reached the required standard.

The presence of the symbol is an indication to the purchaser or user that the product or service has been made under a system of quality control that is defined and audited by NSAI.

NSAI IRISH STANDARD CERTIFICATION MARK

NSAI's Irish Standard certification mark was created to do two things: identify the bearer as Irish Standard certified; and identify NSAI's role as certifier and standards guardian.

It is essential that the mark is always reproduced and displayed correctly. Artwork is issued and controlled by NSAI, do not attempt to recreate or alter supplied artwork.

NSAI IRISH STANDARD CERTIFICATION MARK

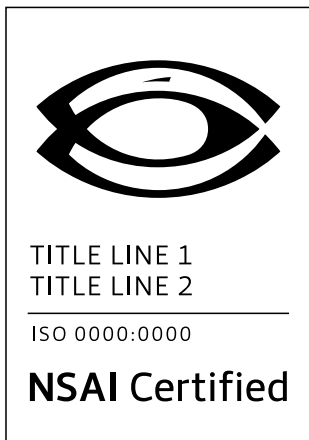

————— Irish Standard symbol

————— Title of certified standard

————— Code reference number of certified standard

————— NSAI endorser

NSAI LOGO & THE CERTIFICATION MARK



Where possible, it is preferred that the NSAI logo is placed next to the certification mark. This will give extra gravitas to the certification mark and assist in building awareness of it.

NSAI's logo can be downloaded online, it should be placed at an equal height, and right alongside the NSAI Irish Standard certification mark.

SMALL USAGE VARIATION

The assortment of objects, products and areas where the certification mark is being applied is becoming more diverse everyday. NSAI recognises this fact and that correct application may not always be possible. Therefore, under circumstances where space limits application, this small usage version may be used to ensure the title and code are legible.

SMALL USAGE VARIATION

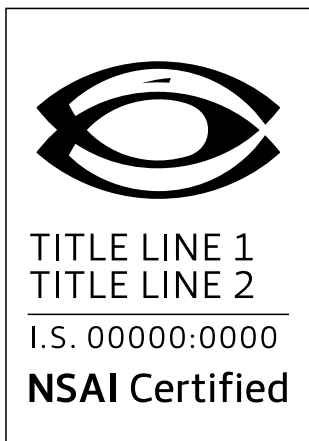

Irish Standard symbol



Enlarged title of certified standard



Enlarged code number of certified standard



NSAI endorser

NSAI LOGO & SMALL USAGE VARIATION

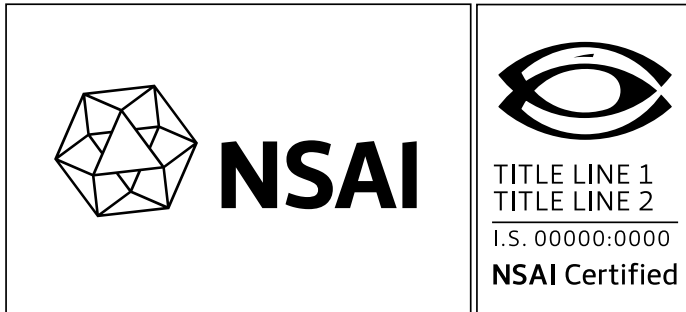

Again where possible, it is preferred that the NSAI logo is placed next to the certification mark. This will give extra gravitas to the certification mark and assist in building awareness of it.

NSAI's logo can be downloaded online, it should be placed at an equal height, and right alongside the small usage variation.

APPLICATION GUIDELINES

When applying the mark, please refer to these guidelines regarding multiple certifications, placement, minimum size, colour usage and co-branding.

Please be aware that NSAI reserves the right to request that certification marks incorrectly applied, or in violation of these guidelines be removed.

MULTIPLE CERTIFICATIONS

An increasing number of products, services and businesses are achieving certification for many different things – sometimes related to each other and other times not. To deal with this in a logical manner, the following method should be applied to distinguish each certification mark.

MULTIPLE CERTIFICATIONS

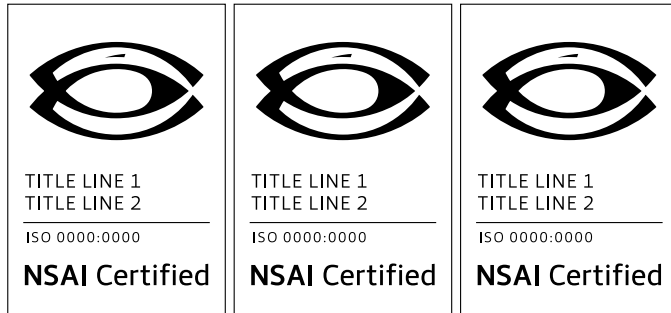

Each certification should be placed side by side as shown left, regardless of how many. This applies to both regular and small usage variations. Even when using the NSAI logo, the multiple certifications should be applied on its right in the same way.

Please note, altering the artwork of one certification to include details of another is unacceptable.

MINIMUM SIZE

The primary mark has no limit as to how large it can be applied, however it isn't allowed to appear smaller than the size indicated here. This ensures the text and standards codes are always legible. For sizes smaller than this, please use the small variation.

Always scale the lock-up proportionally, avoiding stretching or squeezing.

MINIMUM SIZE – CERTIFICATION MARK

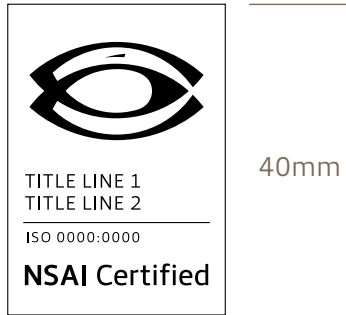

To ensure that the certification mark is always clearly visible and readable, the certification mark must not be used at a size smaller than 40mm high. This includes when used with the NSAI logo.

For any applications that require a smaller mark, the *small usage variation* should be used – see next page for details.

MINIMUM SIZE – SMALL USAGE VARIATION

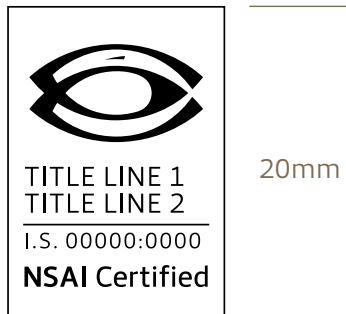

To ensure that the certification mark is always clearly visible and readable, the small usage variation must be used for applications smaller than 40mm high. This includes when it is used with the NSAI logo.

The small usage variation can be used down to a minimum size of 20mm high.

PLACEMENT

When applying the mark it is essential that a minimum clear space area, guarding against the encroachment of other elements is maintained. This ensures visual recognition and clarity is kept to a maximum. Please note that co-branding is an exception to this rule. An example is shown of vehicle application.

PLACEMENT – CLEARSPACE INDICATED BELOW

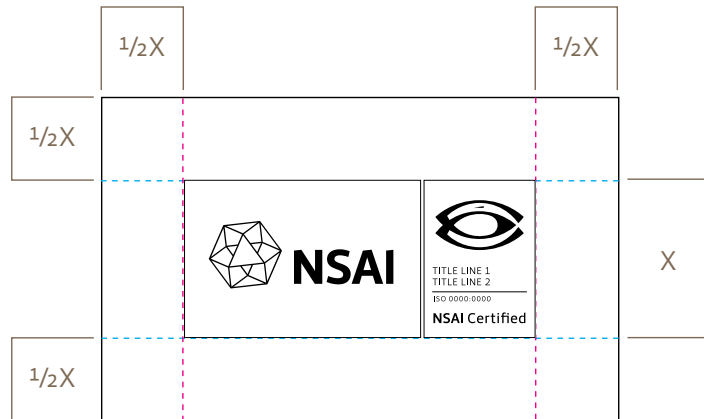
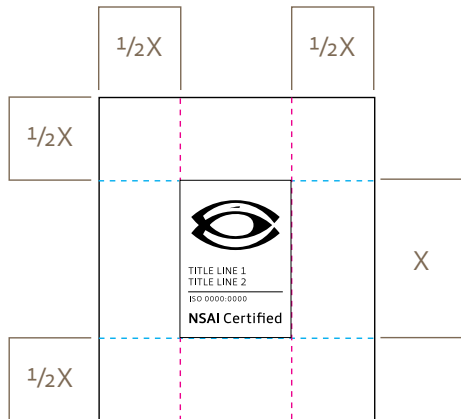

PLACEMENT – VEHICLE EXAMPLE

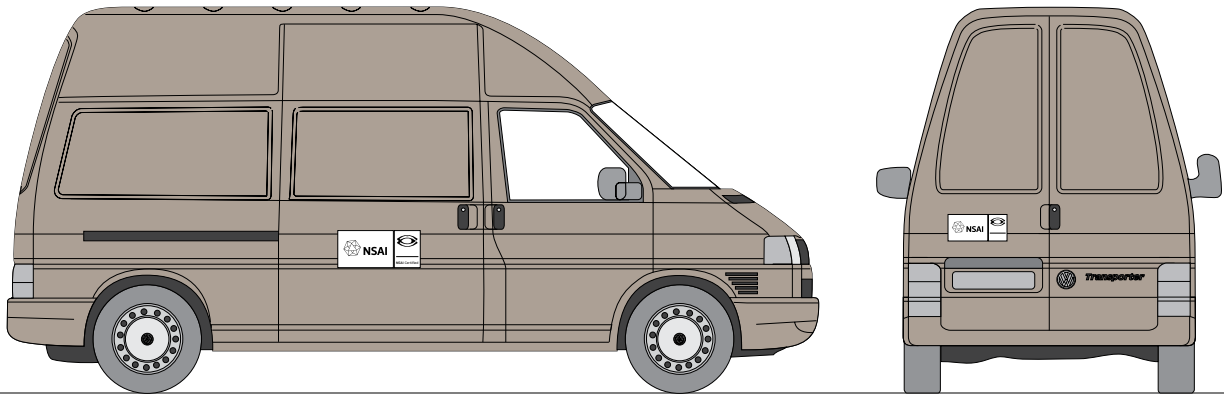

COLOUR USAGE

To ensure visual clarity and consistency, the mark and its small usage variation should only appear black with a white background. An example of placing it on a coloured vehicle is shown on the next page. If in doubt, please contact NSAI for clarification.

COLOUR USAGE – EXAMPLE



TITLE LINE 1
TITLE LINE 2

ISO 0000:0000

NSAI Certified

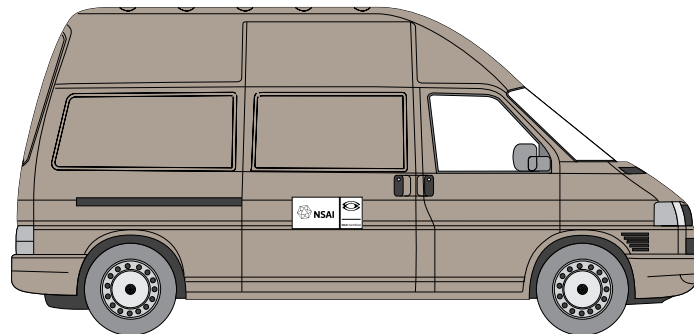

CO-BRANDING

Please observe the application guideline given in document number MK-00-02. The illustration on the following page is for spacing and layout guidance only. Note the NSAI mark should always appear on the left.

CO-BRANDING – SPACING REQUIREMENT REFERENCE

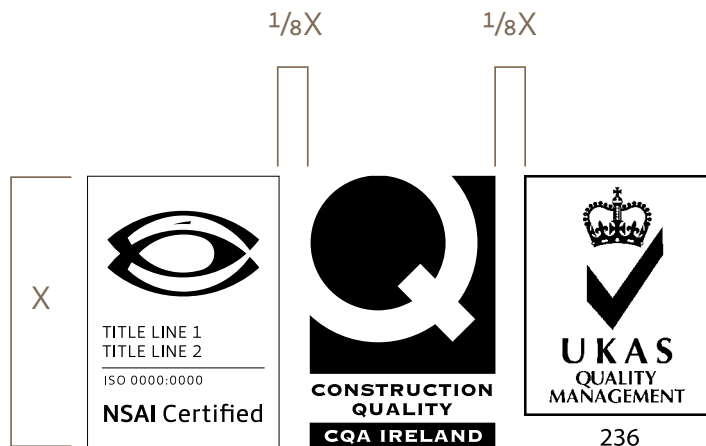

INCORRECT USAGE

Please avoid these common mistakes when applying the mark.

Please be aware that NSAI reserves the right to request that any incorrectly applied, or in violation of these guidelines be removed.

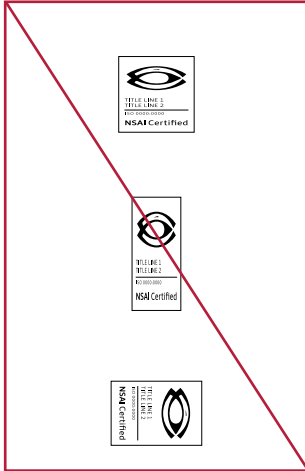

Do not distort, squeeze or rotate the mark.

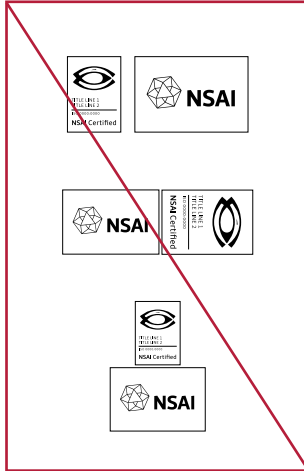

Do not place the mark or NSAI logo in any other arrangement.

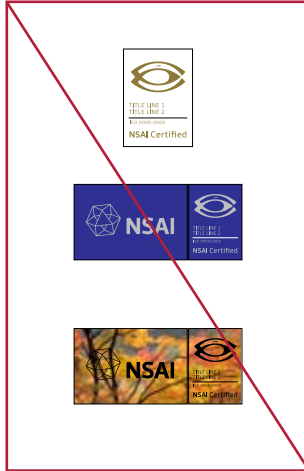

Do not re-colour or apply the mark or NSAI logo to a background with poor contrast.

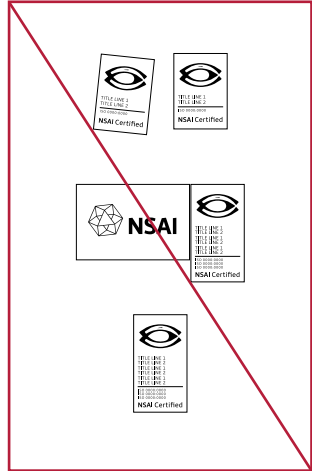

Do not attempt to alter text of the mark or re-arrange multiple certifications.

THANK-YOU

Thank-you for taking the time to read these guidelines. Your commitment to achieving and maintaining the most respected quality system in Ireland will be more greatly recognised by industry and the public by adhering to the guidelines. Recognition of the certification mark can only be strengthened through consistent and correct application.

If you have any further questions or would like to find out more please contact NSAI.

NSAI

1 Swift Square,
Northwood, Santry,
Dublin 9, Ireland

T +353 1 807 3800

F +353 1 807 3838

E info@nsai.ie

NSAI.ie